

ADPRO[®] PRO 

Passive-Infrared Perimeter
Intrusion Detection Systems
(PIR PIDS)

Installation Guide

July 2018

Document: 27386_07

Intellectual Property and Copyright

This document includes registered and unregistered trademarks. All trademarks displayed are the trademarks of their respective owners. Your use of this document does not constitute or create a licence or any other right to use the name and/or trademark and/or label.

This document is subject to copyright owned by XtralisAG ("Xtralis"). You agree not to copy, communicate to the public, adapt, distribute, transfer, sell, modify or publish any contents of this document without the express prior written consent of Xtralis.

Disclaimer

The contents of this document is provided on an "as is" basis. No representation or warranty (either express or implied) is made as to the completeness, accuracy or reliability of the contents of this document. The manufacturer reserves the right to change designs or specifications without obligation and without further notice. Except as otherwise provided, all warranties, express or implied, including without limitation any implied warranties of merchantability and fitness for a particular purpose are expressly excluded.

General Warning

This product must only be installed, configured and used strictly in accordance with the General Terms and Conditions, User Guide and product documents available from Xtralis. All proper health and safety precautions must be taken during the installation, commissioning and maintenance of the product. The system should not be connected to a power source until all the components have been installed. Proper safety precautions must be taken during tests and maintenance of the products when these are still connected to the power source. Failure to do so or tampering with the electronics inside the products can result in an electric shock causing injury or death and may cause equipment damage. Xtralis is not responsible and cannot be held accountable for any liability that may arise due to improper use of the equipment and/or failure to take proper precautions. Only persons trained through an Xtralis accredited training course can install, test and maintain the system.

Liability

You agree to install, configure and use the products strictly in accordance with the User Guide and product documents available from Xtralis.

Xtralis is not liable to you or any other person for incidental, indirect, or consequential loss, expense or damages of any kind including without limitation, loss of business, loss of profits or loss of data arising out of your use of the products. Without limiting this general disclaimer the following specific warnings and disclaimers also apply:

Fitness for Purpose

You agree that you have been provided with a reasonable opportunity to appraise the products and have made your own independent assessment of the fitness or suitability of the products for your purpose. You acknowledge that you have not relied on any oral or written information, representation or advice given by or on behalf of Xtralis or its representatives.

Total Liability

To the fullest extent permitted by law that any limitation or exclusion cannot apply, the total liability of Xtralis in relation to the products is limited to:

- i. in the case of services, the cost of having the services supplied again; or
- ii. in the case of goods, the lowest cost of replacing the goods, acquiring equivalent goods or having the goods repaired.

Indemnification

You agree to fully indemnify and hold Xtralis harmless for any claim, cost, demand or damage (including legal costs on a full indemnity basis) incurred or which may be incurred arising from your use of the products.

Miscellaneous

If any provision outlined above is found to be invalid or unenforceable by a court of law, such invalidity or unenforceability will not affect the remainder which will continue in full force and effect. All rights not expressly granted are reserved.

Document Conventions





The following typographic conventions are used in this document:

Convention	Description
Bold	Used to denote: emphasis Used for names of menus, menu options, toolbar buttons
<i>Italics</i>	Used to denote: references to other parts of this document or other documents. Used for the result of an action.

The following abbreviations are used in this document.

Abbreviation	Description
AA	Aperture Angle
CZ	Creep Zone
PID	Perimeter Intrusion Detector
PIDS	Perimeter Intrusion Detection System
PIR	Passive-Infrared

The following icons are used in this document:

Convention	Description
	CAUTION! This icon is used to indicate that there is a danger to equipment. The danger could be loss of data, physical damage, or permanent corruption of configuration details..
	DANGER! This icon is used to indicate that there is a danger of electric shock. This may lead to death or permanent injury.
	WARNING! This icon is used to indicate that there is an immediate danger of falling, which may lead to death or permanent injury, such as if unsecured ladders that can slip are used. Additional information: also see guidelines on “Workplace Safety” applicable locally.
	NOTE! This icon is used to highlight useful advice and recommendations as well as information for an efficient and trouble-free operation.

Contact Us

UK and Europe	+44 1442 242 330
The Americas	+1 800 229 4434
Middle East	+962 6 588 5622
Asia	+86 21 5240 0077
Australia and New Zealand	+61 3 9936 7000
www.xtralis.com	

This page is intentionally left blank.

Table of Contents

1	General Notes	8
1.1	Information about this guide	8
1.2	Warranty	8
1.3	Customer service and product monitoring	8
1.4	Device variants	9
1.5	Scope of delivery	9
1.6	Accessories	9
1.7	Designated use	10
1.8	Applicable documents	11
1.9	Safety precautions	11
1.10	Environmental protection	12
1.11	Transportation, packaging and storage	12
2	Device description	14
2.1	Alarms	14
2.2	Overview of the circuit board	15
2.3	Interaction with accessories	16
2.4	Commissioning accessories	16
3	Safety	18
3.1	Notes on cabling	18
3.2	Lightning and overvoltage protection	19
4	Before mounting – detector address and basic configuration	22
4.1	Connect single detector to IFM-485-ST interface module	22
4.2	Establish connection from PC via IFM-485-ST	23
4.3	Configure detectors	25
4.4	Configure other detectors of an installation	26
5	Mounting	28
5.1	Assembly material and tools	28
5.2	Pole mounting of detector holder	30
5.3	Wall installation of detector holder	32
5.4	Installation of detector in detector holder	33
6	Installation	36
6.1	Connect detector	36
6.2	Fine adjustment of tamper switch	41
6.3	Connect detectors to IFM-485-ST	42
6.4	Final check of the basic installation	43
6.5	PRO E-RF installation steps	45
7	PRO E-IPM (IP module)	52
7.1	System overview	52
7.2	Install IP module	53
7.3	Setup IP module	54
7.4	Connect multiple IP modules	61
7.5	Connect multiple detectors to one IP module	62
7.6	Reset IP module	63
8	Detector alignment	64
8.1	Installation of the telescope	64
8.2	Alignment with the help of the telescope	65
8.3	iCommission (one-person commissioning)	66
8.4	CT PRO 2 – wireless walk tester	71
8.5	After alignment	74

9	Technical data	76
10	Maintenance and cleaning	78
10.1	Firmware update (ADPRO flashloader)	78
10.2	Replace filter	80
10.3	Retrofit creep zone blinder	81
11	Troubleshooting	84
11.1	No detectors found in ADPRO PRO E-Tool	84
11.2	Specific detector not found in ADPRO PRO E-Tool	85
11.3	Polarity mismatch	86
11.4	Troubleshooting in firmware update (ADPRO flashloader)	86
11.5	False alarms	87
12	Dismantling and disposal	88
12.1	Work safety	88
12.2	Measures before dismantling	88
12.3	Disposal	88
13	Declaration of Conformity	90

1 General Notes

1.1 Information about this guide

Use of the guide	This guide provides information for the safe and efficient installation/handling of the device. For defect-free functioning of the device, all instructions in this guide must be followed.
Compulsory reading	This guide must be read carefully before installation of the device.
Diagrams in this guide	The diagrams in this guide are for a basic understanding only and may differ depending on the version of your device.
Loss of guide	A replacement copy can be ordered from Xtralis if this guide is lost, or downloaded from the Xtralis Security Solutions Support site at www.xtralissecurity.com . You can find contact details on page 11.
Information in this guide	The information and safety instructions in this guide were composed in accordance with the latest standards, guidelines and rules and the state of the technology, and are based on many years of experience. The materials delivered with the device or the device features may differ from the descriptions and diagrams in this guide, depending on whether any optional items have been ordered, or special versions have been manufactured, or if there have been recent technical changes.

1.2 Warranty

Terms of Warranty	The terms of warranty are defined in the sales agreement and in the manufacturer's general terms of business.
Preconditions	The manufacturer is entitled to a final decision on a warranty claim in respect of the return of defective parts (if necessary after a test on site). The warranty period for the device does not get extended when defective parts are replaced. All changes or major repairs by the user or a third party without the written approval of the manufacturer will lead to a cancellation of the warranty.

1.3 Customer service and product monitoring

Customer Service	For errors and problems which cannot be rectified with the help of the information in this guide, or for technical questions, please contact our customer service. You can find contact details on page 4.
Product Monitoring	Our aim is to improve our products continually. We are therefore interested in your experience with the product. We welcome your feedback regarding any malfunctioning of the device during the use of the product. Please inform the manufacturer of any incidents or malfunctioning.

1.4 Device variants

	Type	Art no.
PRO E -45 Detection range 50 x 3.3 m, front window HDPE filter	Curtain	CH10023001
PRO E -45 D Detection range 50 x 3.6 m, front window HDPE filter		CH10023201
PRO E -45H Detection range 60 x 3.9 m, front window silicon wafer filter		CH10023101
PRO E -45DH Detection range 60 x 4.2 m, front window silicon wafer filter		CH10023301
PRO E -100 Detection range 120 x 2.7 m, front window HDPE filter		CH10033001
PRO E -100H Detection range 150 x 3.3 m, front window silicon wafer filter		CH10033101
PRO E -400H Detection range 220 m x 5.1 m, front window silicon wafer filter		CH10100001
PRO E -18 Detection range 24 x 21 m, front window HDPE filter	Volumetric	CH10055001
PRO E -18H Detection range 30 x 27 m, front window silicon wafer filter		CH10055101
PRO E -18W Detection range 21 x 24, wide-angle 90°, front window HDPE filter		CH10053001
PRO E -18WH Detection range 27 x 30, wide-angle 90°, front window silicon wafer filter		CH10053101
PRO E -30 Detection range 30 x 20 m, front window HDPE filter		CH10063001
PRO E -40 Detection range 40 x 10 m, front window HDPE filter		CH10073001

1.5 Scope of delivery

In addition to the actual detector the scope of delivery includes a detector holder with:

- Panels
- Cable seal
- Moulding: straight and rounded
- Hexagon socket screws with washers

Required tools are referred to in the respective sections on mounting, connection and alignment of the detector, refer to "Required tools (not in scope of delivery)".

Not included in the scope of delivery are:

- Screw clamps (pole mounting, refer to "Pole mounting of detector holder")
- Locking screws (wall installation, refer to "Wall installation of detector holder")
- Cabling (refer to "Recommended cables")

1.6 Accessories

Available accessories	Art. no.	Description
Front window	CH11001001.	Front window HDPE filter, 10 Stk.
	CH11001101	Front window silicon wafer filter

PRO E IP module	CH12005001	Plug-in IP module for installation in an ADPRO PRO E-PIR Tool -detector, allows alarm management and remote access via IP
IFM-485-ST interface module	CH19000301	RS -485 to RS -232/USB interface module, for bi -directional communication with up to 128 detectors, with connection cable and software CD.
CT PRO 2 walk tester	202483	Wireless walk tester, 150m, 2.4GHz
Cable	CH12001001	PRO E -IFC -RS -485 interface cable for PRO E -detectors to CT PRO 2 walk tester and IFM-485-ST USB interface module
iCommission alignment tool	CH12003001	Alignment tool for remote vertical adjustment of detectors via WiFi. Control is via free iCommission app (iOS).
Alignment telescope for PRO series	242600	AD 851 telescope for precise alignment of medium range and long range curtain detectors of the ADPRO PRO and Intrinsically Safe.
Alignment telescope PRO E series	CH18000101	Telescope and adapters for PRO E detectors
Adapters telescope	CH11001201	Adapters for PRO E detectors (without telescope) -pair for one telescope

Wireless accessories for RF variants

Available accessories	Art. no.	Description
Stand-alone receiver	CH12101001.	EE4216MR Stand Alone Receiver, 868 MHz, 16 detectors, 5 OC-Outputs (free programmable)
	CH12101101	EN4216MR Stand Alone Receiver, 900 MHz, 16 detectors, 5 OC-Outputs (free programmable)
	CH12102001	EE4232MR Stand Alone Receiver, 868 MHz, 32 detectors, 12 OC-Outputs (free programmable)
	CH12102101	EN4232MR Stand Alone Receiver, 900 MHz, 32 detectors, 12 OC-Outputs (free programmable)
Repeater	CH12103001	EE5000 High Power Repeater, 868 MHz Innovonics EchoStream
	CH12103101	EN5040 High Power Repeater, 900 MHz Innovonics EchoStream
PRO E - IFM-RF RF interface module	CH12100001 USB	USB interface module for configuration of wireless PRO E detectors

1.7 Designated use

Xtralis ADPRO detectors are designed to detect the presence in sensitive areas of individuals without access authorization (in this guide referred to as "intruder") and to take responsive action, e.g. by activating camera monitoring for a further analysis of the event.

1.8 Applicable documents

1.8.1 Guides

- ADPRO PRO E Introduction to PIR Technology Guide, document no. (27385)
- ADPRO PRO E PIR System Setup Guide, document no. 26571
- ADPRO PRO E PIR System Design and Planning Guide, document no. (27387)
- VdS Directive System Components for Perimeter Monitoring VdS3456
- prEN50606 External Perimeter Security Systems (in development)

1.8.2 Xtralis Websites

www.xtralis.com

Xtralis Security Solutions Support Site

www.xtralissecurity.com

You can find data sheets as well as commercial information in the public area of the website. Registration is free, and our partners have access to detailed information such as guides, Xtralis white papers, presentations, images, videos, certificates, as well as software and drivers free of charge.

Landing page ADPRO PRO E Passive-Infrared Detectors

www.xtralis.com/adpro_pro_e_detectors

Xtralis Product Videos

www.xtralis.com/video.cfm

1.9 Safety precautions

This section contains an overview of all important safety precautions to be taken for smooth and reliable operation.

Non-observance of the instructions/warnings in this guide can lead to injury or death.

1.9.1 Responsibilities of the User

General	The safety instructions in this guide are meant to ensure user safety and prevent accidents. In addition, environmental protection standards must be taken into consideration in positioning the device.
Defect-free technical condition	To guarantee that the device remains in defect-free technical condition, the maintenance instructions described in this guide must be followed.

1.9.2 Personnel requirements and qualifications

This guide assumes the following qualifications for the various tasks described in the guide:

Electricians	Electricians having the educational background, experience and knowledge of standards, regulations and procedures that qualify them to work on electrical systems and risk detection.
System integrators	Skilled system integrators having the educational background, experience and knowledge of standards, regulations and procedures which qualify them for work on alarm/IT systems and risk detection.

1.10 Environmental protection

1.10.1 Damage to environment

**CAUTION:**

Risk to environment through improper use!

Improper use of substances that are hazardous to the environment, and in particular their improper disposal, can cause substantial environmental damage.

Hence:

- Always follow the instructions in this guide
- Initiate appropriate measures immediately if environmentally hazardous substances are released into the surroundings. Inform the responsible local authority of the damage in case of doubt.

1.11 Transportation, packaging and storage

1.11.1 Transportation

Note: To prevent damage, all components should always be transported in their original packaging.

1.11.2 Packaging

- **Packaging**

Detectors and their accessories have been adequately packaged for proper transportation/warehouse storage. Only eco-friendly materials have been used for packaging.

Packaging protects against damage during transit, corrosion and other damage, and should not be destroyed or disposed off.

- **Handling packaging materials**

If packaging materials are no longer needed nonetheless, you must dispose of the packaging materials in keeping with applicable statutory regulations and local guidelines.

**CAUTION:**

Environmental damage through improper disposal!

Packaging materials are valuable raw materials which can often be used, recycled and reused in many instances. Please dispose of packaging materials in an environmentally friendly manner.

Please comply with local disposal regulations.

- **Unpacking**

Detectors are typically delivered as an individual product along with instructions for use; no further documentation comes with the product. Documentation and resources, such as the latest version of the planning and installation guide, ADPRO PRO PIR e-data sheets and e-brochures, drivers and software tools etc., can be downloaded free of cost from the Xtralis Security Solutions Support Site at www.xtralissecurity.com

While unpacking the detector, please take the usual electrical and electrostatic (ESD) precautions by providing sufficient earthing, and observe applicable work safety guidelines.

**CAUTION:**

Dismantling the detector may lead to permanent damage or even loss of warranty.

Operating a detector outside the operating voltage or temperature range specified for it can also lead to permanent damage.

A detector contains sensitive electrostatic components and should be handled accordingly.

This page is intentionally left blank.

2 Device description

Passive infrared detectors are designed for outdoor motion detection using passive infrared technology (PIR) and high-precision mirror optics. The device senses temperature differences between moving objects and a stationary background. The detector adapts the threshold level responding to external influences such as environmental effects, temperature changes. The device is offered in a variety of models covering a length of up to 150 m (500 ft) and a width of 30 m (100 ft). Curtain detector models (long-range and medium-range curtain detectors) monitor a long and narrow detection range. Volume detectors monitor the inside of a perimeter.

The housing and the mounting bracket are designed for both wall and pole mounting; no additional adapters required. The integrated cable management provides for invisible cable routing directly from the mounting surface.

PRO E-RF detectors with integrated Ivonics RF module EN1941 for North America/Australis, New Zealand or EE1941 for Europe are based on same technical specifications as wired models.

These detectors transmit alarms and fault messages one way wireless to an Inovonics receiver e.g. EE4232MR/EN4232MR or EE4216MR/EN4216MR. The EchoStream Commercial Mesh Network's backbone of intelligent repeaters EE5000/EN5000 can extend coverage to thousands of sensors across entire commercial premises. Refer to "PRO E-RF installation steps".

For immediate operability after connection all outputs are set to standard-compliant default values. If required, the default settings can be changed using the ADPRO PRO E software, refer to ADPRO PRO E PIR System Setup Guide, document no. 26571.

Reliable creep zone detection thanks to creep zone blinder

The new creep zone concept eliminates strong lateral IR radiation. The blinders make the detection more reliable and unsusceptible against false alarms caused by, e.g., big lorries, generators or machines which are directly located in the direct proximity of the PIR detector.

IP66 protection

Almost all detector models feature IP66 protection, refer to the list below.

The housing with protection class IP66 ensures protection against dust and water ingress even in adverse weather conditions. Thanks to the wide temperature range of operation from -40 °C to +60 °C (-40 °F to +140 °F) and thanks to IP66 protection the ADPRO PRO E range is suitable for almost all outdoor environments and in a variety of applications in dry and humid climates.

The following detectors provide IP66 protection:

- PRO E-18 (CH10055001)
- PRO E-18H (CH10055101)
- PRO E-18W (CH10053001)
- PRO E-18WH (CH10053101)
- PRO E-30 (CH10063001)
- PRO E-40 (CH10073001)
- PRO E-45 (CH10023001)
- PRO E-45DH (CH10023301)
- PRO E-45H (CH10023101)
- PRO E-100 (CH10033001)
- PRO E-100H (CH10033101)

2.1 Alarms

In the detection perimeter 4 alarm zones are provided for detection of alarms.

- Creep zone
- Infrared main zone, depending on the model with differentiated short, medium, and long range zones

The comprehensive tamper protection includes the followings aspects which trigger an alarm:

- Opening of detector housing and mounting bracket cover
- Changes in position (multidimensional: tilting, rotating, swivelling)
- Slow horizontal movements with the help of an integrated switchable digital compass
- Attempts to remove the device from the mounting surface
- Masking: monitoring whether the device is covered by curtains or boxes

All ADPRO PRO E detectors provide 3 freely programmable outputs for the following events:

- Alarm PIR sensor, 360PROtect™ or masking monitoring
- Fault events caused by the power supply, exceeded temperatures, faulty heating device, masking monitoring or watch-dog
- Tamper alarms of housing cover, cable managed bracket cover, misalignment and attempts to remove the device from the mounting surface

High-performance detectors (H versions) have two additional freely programmable alarm outputs for e.g.:

- 360PROtect™
- Masking
- Alarm zones
- or other events

2.2 Overview of the circuit board

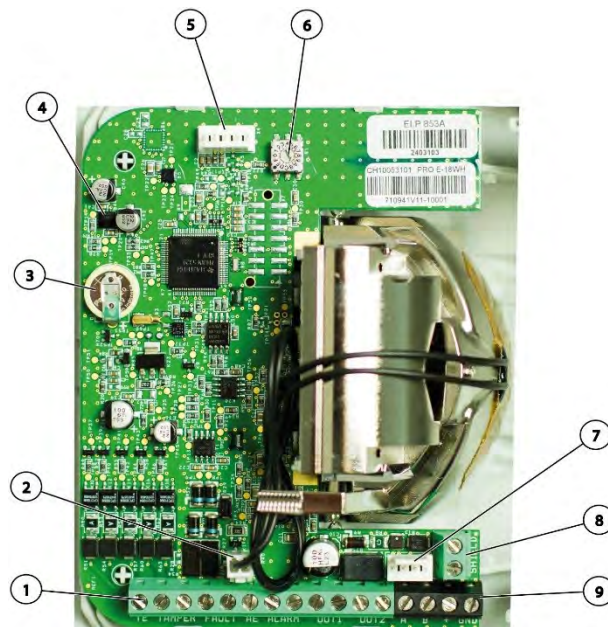

1. Alarm output terminal
2. Heating terminal
3. Backup battery
4. Light-sensitive proximity sensor
5. Tamper switch socket
6. Rotary switches (do not change)
7. Test (bus/power) or IP module (optional) socket
8. Shield terminal
9. Bus/Power supply terminal

Pin assignment alarm outputs

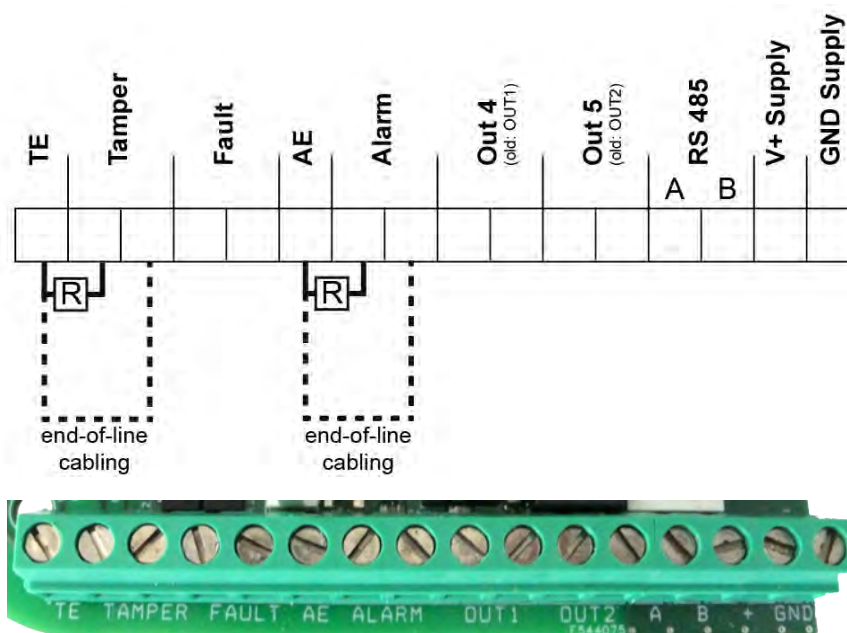

PCB-Terminal	
TE	tamper end-of-line
Tamper	tamper output
Fault	fault output
AE	alarm end-of-line
Alarm	alarm output
Out 4	free programmable output
Out 5	free programmable output
RS 485	RS-485 terminal
V+ Supply	power supply (+)
GND Supply	power supply (-)

2.3 Interaction with accessories

IP module (PRO E detectors)

Das IP module PRO E-IPM is an accessory part converting RS-485 bus to Ethernet. This allows alarm management and remote access to PRO E detectors via the IP module's IP address. The IP module is supplied with electricity via an external PoE connection.

For details refer to chapter "PRO E-IPM (IP module)".

Interface module IFM-485-ST

Using the IFM-485-ST up to 128 detectors can be configured and monitored from one PC. The detectors are connected via RS-485 and IFM-485-ST via USB or RS-232 to the PC. For details refer to chapter "Before mounting – detector address and basic configuration".

2.4 Commissioning accessories

Commissioning of detectors is possible by a single person. This is supported by the following accessories, which are specifically designed to meet the demands when aligning detectors:

- Telescope
For basic alignment of detectors by bearing.

- iCommission
Alignment tool and app for remote mechanical vertical alignment (one-man-commissioning) of the detector.
- CT PRO 2 walk tester
Test tool for remote testing of alarms

For details refer to chapter "Detector alignment"

3 Safety

The safety notes in this chapter apply to all work with and on all kinds of detectors.

**WARNING:**

The device must not be used in potentially explosive areas, or areas where work with hazardous substances is being carried out. Intrinsically safe models are available (IS family of products).

**WARNING:**

Risk of injury due to improper installation and commissioning!
Improper installation and commissioning can result in serious injury or damage.
Hence:

- Work on the electric system may only be carried out by qualified electricians.
- Mind openly accessible, sharp-edged parts.

**WARNING:**

Danger of falling!
Immediate danger when working with unsecured ladders. Unsecured ladders can slip resulting in falling with consequential serious injuries.
Hence:

- Safe access must be provided to all working platforms, scaffolding and other places of work.
- All locations where work is performed and the access to the workplaces must be sufficiently well-lit.
- All ladders must be secured and they must be long enough to provide secure support for hands and feet at all locations used.

**WARNING:**

Independent of the above safety notes all relevant local guidelines regarding "Occupational Health and Safety" must always be observed.

Notes:

- Before installation, make sure the device has not been damaged during transportation.
- Before installation, make sure that all transport packaging and/or transport safeguards have been removed from the device.

3.1 Notes on cabling

To prevent water ingress, ensure the following:

- Avoid assembly in rain and protect against rain by appropriate means
- Make sure you observe minimum cable diameter
- Always place the plastic safety washer into the unused screwed cable gland correctly.

When preparing the detector assembly, comply with local cable installation regulations and applicable industry standards. In particular, standard minimum distances must be observed in the vicinity of electric high-power lines, because line signals may otherwise be affected potentially resulting in inaccurate measurements or even false alarms.

3.2 Lightning and overvoltage protection



CAUTION:

To protect detectors from permanent damage due to a direct lightning strike when mounted on a pole, detectors (or other devices such as camera or IR lighting) must never be mounted directly at the top of the pole. Instead a custom-calculated safety distance must be observed above the detector.

If this safety distance is not possible due to the conditions on location (pole too short, for example), extensive lightning protection measures, such as installing air terminal rods must be taken as shown above.

Regarding lightning protection the following standards also have to be complied with:

- DIN CLC/TS 61643-12 (VDE V 0675-39-12):2010-09: Overvoltage protection devices for L.T. - Overvoltage protection devices for specific applications, including DC voltage. Section 12 - Principles of selection and use – Overvoltage protection devices for use in photovoltaic installations
- IEC 62305 (international) or EN 62305 (Europe) Lightning Protection
 - Section 1 - General principles
 - Section 2 - Risk Management
 - Section 3 - Protection of building installations and people
 - Section 4 - Electrical and electronic systems in building installations
- EN 61663-2 Lightning Protection – Telecommunications cables
 - Section 2 - Cables with metallic conductors
- EN 61643-11 Overvoltage protection devices for L.T.
 - Section 11 - Overvoltage protection devices for use in L.T. systems - standards and test procedures
- EN 61643-21 Overvoltage protection devices for L.T.
 - Section 21 - Overvoltage protection devices for use in telecommunications and signal-processing networks – performance standards and test procedures

These notes do not claim to be complete and must be possibly supplemented in relation to other local, national and international standards (such as VdS Guideline VdS 2833, overvoltage protection measures for alarm/fire extinguisher control systems or VdS Safety Guidelines Perimeter VdS 3143).

Recommendation

For more information and professional advice you may contact the following manufacturer:

DEHN + SÖHNE GmbH + Co.KG.
 Hans-Dehn-Str. 1
 D-92318 Neumarkt
 Postfach 1640
 D-92306 Neumarkt

Phone: 0049 (0)9181 906-0
Fax: 0049 (0)9181 906-1100
E-mail: info@dehn.de
Contact: www.dehn.de/de/kontakt

This page is intentionally left blank.

4 Before mounting – detector address and basic configuration

Notes:

- In an installation each detector connected to a bus must have its unique address. All detectors are supplied with address 1 as factory setting. Therefore, we recommend that before mounting detectors at the installation site you connect the detectors separately to assign an individual address and to check the basic configuration. If detectors with identical addresses are installed then these detectors cannot be found within the system!
- Please ensure that you have the latest version of the drivers and the ADPRO PRO PIR Tool Setup Software_Vx.xx installed on your PC at all times.

This chapter describes how to connect and configure detectors using the IFM-485-ST interface module which is available as accessory. Using the IFM-485-ST you can connect up to 128 detectors to a PC and configure them with the aid of the ADPRO PRO E-Tool. For a complete description of the ADPRO PRO E-Tool refer to the ADPRO PRO E PIR System Setup Guide, document no. 26571.

In the following sections the procedure is first described for connection and configuration of single detectors. The descriptions from the basis for building up systems with several detectors. This is described in the subsequent chapters.

4.1 Connect single detector to IFM-485-ST interface module



WARNING:

Observe the safety notes in the IFM-485-ST Quick Installation Guide (document no. 27178).

The IFM-485-ST is an interface module (RS-485 to RS-232/USB) for bi-directional communication with up to 128 detectors. Using the IFM-485-ST up to 128 detectors can be configured and monitored from one PC. The detectors are connected via RS-485 and IFM-485-ST via USB or RS-232 to the PC.

Proceed as follows:

1. Connect the RS485-BUS of the detector via the green 4-PIN connector on the circuit board or via the A/B connectors of the terminal strip to the IFM-485-ST interface module.
2. Install the PRO software on the PC.
3. Then connect the interface module to the PC using a USB or RS-232 cable.



4. Continue as described in section "Configure Communication Port on PC" and the subsequent sections.

4.2 Establish connection from PC via IFM-485-ST

4.2.1 Configure Communication Port on PC

Note: If your computer has a RS232 data bus, i.e. a serial COM1 or COM2 port, you can connect the IFM-485-ST directly to the serial port of your PC and without additional drivers. The section describes how to connect the IFM-485 via USB including the required configuration of a USB serial port.

Before using the port for the first time the communication port must be configured for the software. Proceed as follows:

1. Start the Windows Device Manager via Start menu, Control Panel, Device Manager.
2. Connect the IFM-485-ST with the available port. Until the device has been recognised it will be listed under "Other devices" as unknown device:

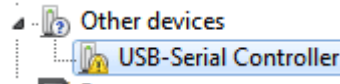

If the device is automatically detected it will be listed under Ports:

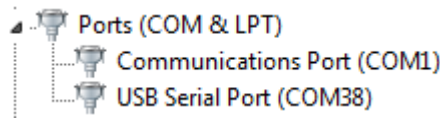

The port number varies depending on the system used.

3. Right-click on the USB port item to open the context menu. Select **Update driver software**.
4. Select **Browse my computer for driver software**.
5. Select the installation directory of the ADPRO PRO E-Tools and activate the **Include subfolder** checkbox.
6. Click on **Next**.
7. Wait until the look-up process has been completed and the update has been confirmed. Then click on **Close**.

The following section "First detector connection" describes the allocation of the communication port to the ADPRO PRO E-Tool.

4.2.2 Install ADPRO PRO E-Tool

Install the software as described in the ADPRO PRO E PIR System Setup Guide, document no. 26571.

4.2.3 First detector connection

Before the ADPRO PRO E-Tool can display meaningful content you have to select the communication port to be used as well as the desired detector. Proceed as follows:

1. Make sure the detector is connected to power supply, and allow enough time for the start-up to be completed. If the detector is activated during the search process, the software might not find it.
2. Start the ADPRO PRO E-Tool.
3. Select communication port:
Select **Options, Com Port** and then the COM port configured for the connection, refer to section "Configure Communication Port on PC" above. The selected port is ticked off.
Note: The number of communication ports varies depending on the system used and the available ports.
4. Select detector:
Select **Options, Search Detector** or press [F3]. The search dialogue is displayed:

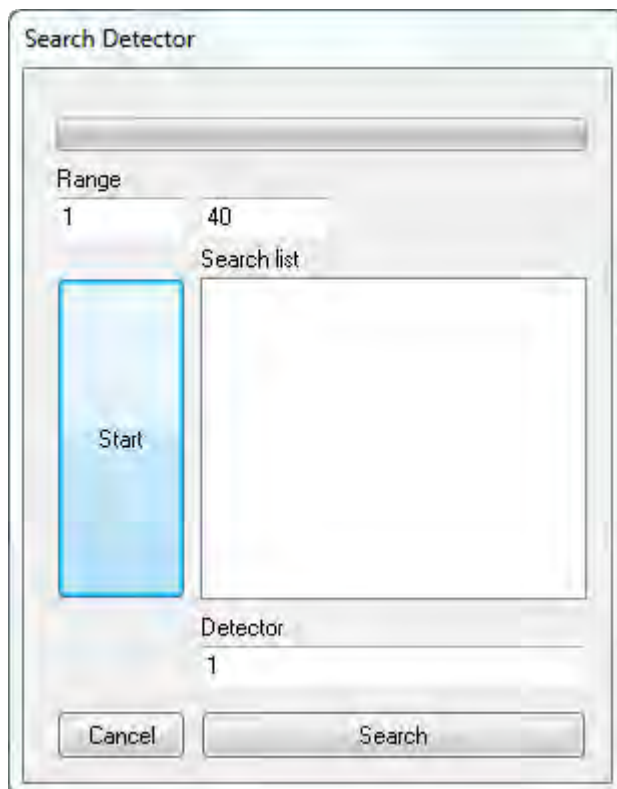

5. Click on **Start**.

You can cancel the ongoing search process by clicking **ESC**.

In the **Search list** shows the detectors found:

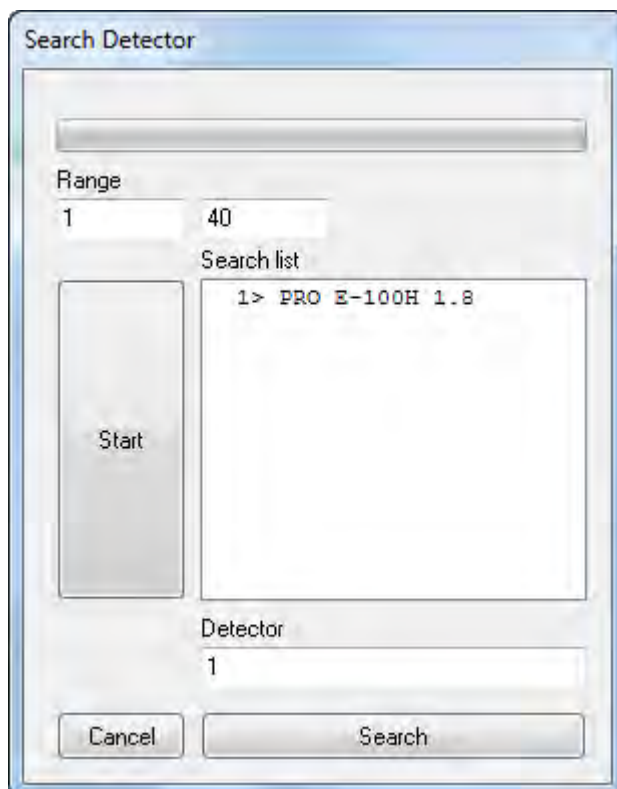

In case of a new detector with factory settings the detector is displayed in the list with address 1. If no detectors could be found, a message is displayed. If several detectors have been connected to the IFM-485-ST it might also happen that there are detector addresses which have been allocated twice so that individual detectors are not listed. Refer to chapter "Troubleshooting".

6. Double-click on the desired item in the list, or enter the detector address (in the example above 1) in the **Detector** field and click **OK**.

The signals of the selected detector are displayed in the ADPRO PRO E-Tool:

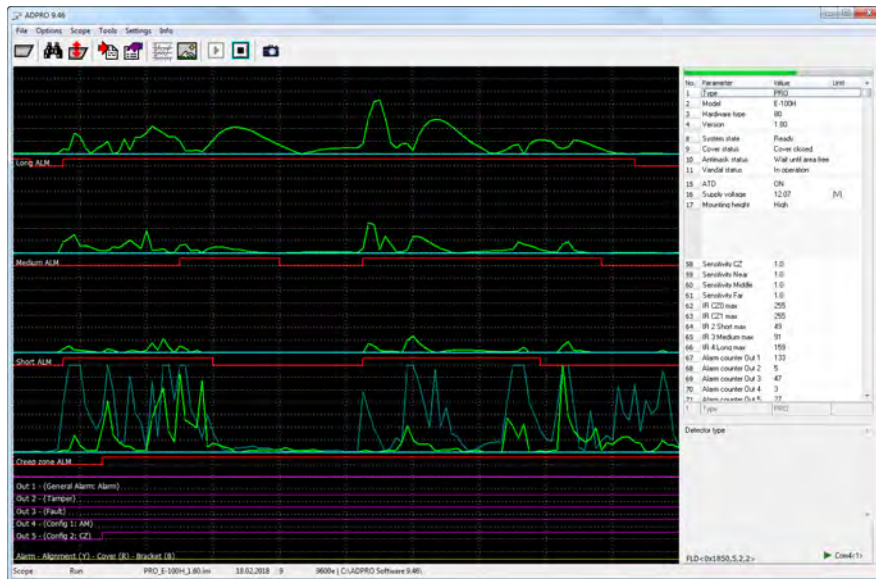

Use the ADPRO PRO E Tool for further configuration of the detector. For details on the ADPRO PRO E-Tool refer to the ADPRO PRO E PIR System Setup Guide, document no. 26571.



4.3 Configure detectors

Notes: Make sure that the latest firmware is installed on every detector. The version currently installed is displayed in the ADPRO PRO E-Tool as Version parameter. The firmware update is described in section “Firmware update (ADPRO flashloader)”.
For details on the Setting dialogue refer to the ADPRO PRO E PIR System Setup Guide, document no. 26571. The hardware-side connection of single detectors is described in section “Connect single detector to IFM-485-ST interface module”.

Proceed as follows when configuring a detector:

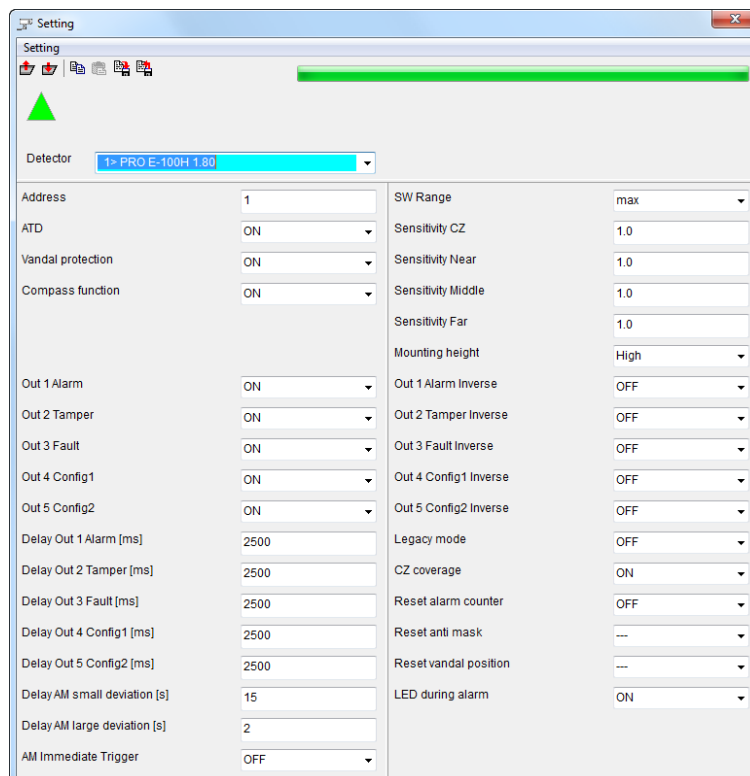
1. To set up the basic settings select **Settings, Settings:**



2. Change the Address to a value between 2 and 255.
Note: Be sure to use a unique value. If multiple detectors are connected using the same Address value, none of the respective detectors will be found. As the factory setting is 1 particularly the value 1 might result in conflicts when connecting additional detectors.
3. Set the values in the dialogue as required.
4. To transfer the settings to the detector, select **Setting, Write settings to detector** (or [Ctrl]+[D]). To discard changes close the dialogue using the icon  (or [Alt]+[F4]) and confirm the confirmation prompt.
5. If you want to transfer the basic configuration to other detectors, select **Setting, Save** (or [Ctrl]+[S]) or click .
6. Enter a meaningful file name and click **Yes**.
The subsequent steps are described in the next section below.

Note: To reset to factory settings select **Setting, Factory** (or [Ctrl]+[F]) and confirm the confirmation prompt. All values except the Address are reset to factory settings.

4.4 Configure other detectors of an installation

To transfer a stored configuration (see above) to other detectors proceed as follows:

1. Remove the first detector from the IFM-485-ST.
2. Connect the second detector as the first one.
3. Establish a first connection to the detector using the ADPROPRO E-Tool.
4. Select **Settings, Settings**.
5. Enter a unique **Address** for this detector.
Note: Use an Address (2-255) which is not already in use. Do not use 1 because this is reserved as factory setting for detectors supplied.
6. To load the basic configuration of the first detector select **Setting, Load from configuration file** (or [Ctrl]+[O]). The following dialogue is displayed in which all stored configurations are listed:

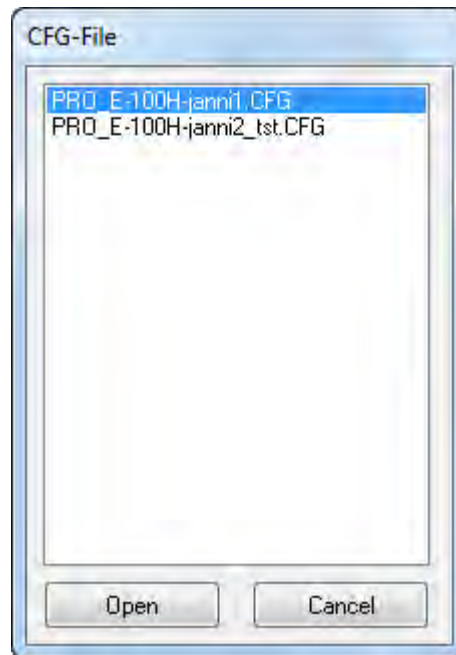

7. Double-click on an item to load the respective settings.
8. To transfer the settings to the detector select **Setting, Write settings to detector** (or [Ctrl]+[D]).
9. Repeat the steps for all other detectors in the installation.

As soon as all detectors are configured according to the requirements, continue mounting and connecting the detectors as described in the following chapters.

5 Mounting



WARNING:

Observe the safety notes in chapter "Safety".

Notes:

- An installation video is available on YouTube, <https://www.youtube.com/watch?v=NbMFwnwgixA>. It is recommended to watch it . For background information on positioning and alignment of detectors refer to ADPRO PRO E PIR System Design and Planning Guide, document no. (27387).
- The range of ADPRO[®] PRO E-detectors offered is extensive, and we can cover only basic mounting here.
- Installation instructions for each product must be followed with respect to detector dimensions, attaching parts and specific features.
- The stipulated mounting height of 2.5 m to 4 m above ground should be maintained. 4 m is the minimum height at which the detector operates at its standard maximum range and is also optimally tamper-proof.

5.1 Assembly material and tools

5.1.1 Assembly material provided

Before installation, check whether all required materials have been supplied with the detector.

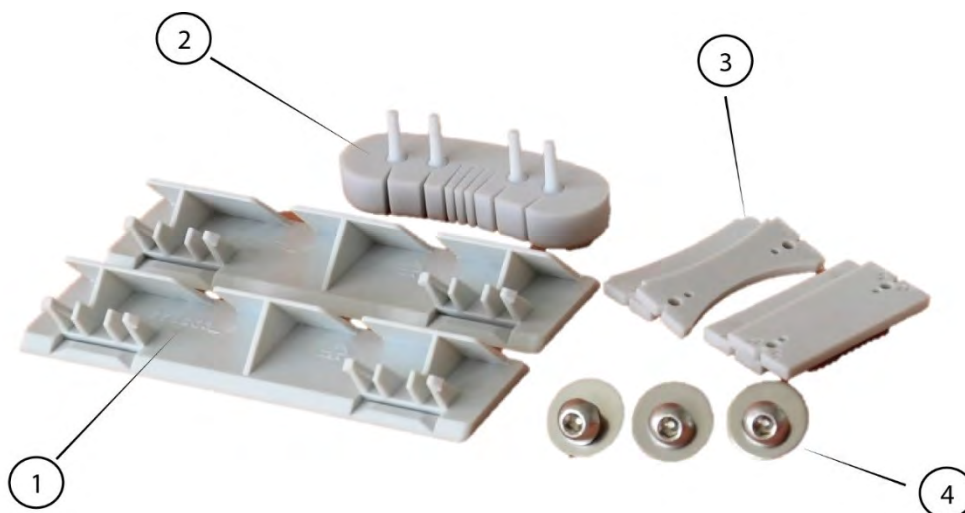

1. Panels
2. Cable seal
3. Molding: straight and rounded
4. Hexagon socket screws with washers

5.1.2 Required assembly material (not in scope of delivery)

Depending on the type of mounting you will need suitable screw clamps (pole mounting straps) as well as the actual pole. In case of wall mounting you need 4 dowels and fastening screws. Use sufficiently long screws with an external diameter of at most 5 mm and a flat screw head. The upper screws should have a threaded length of a min. of 75 mm and the lower screws a min. of 60 mm.

5.1.3 Recommended cables

The following are the cable specifications for PRO E-detectors (cable colours may vary):

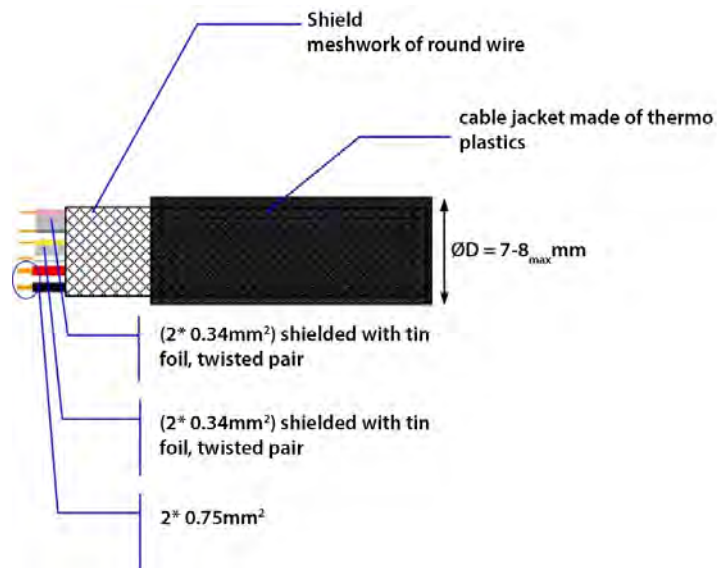

Peak voltage: 50V AC

Temperature range: -40 .. 80°C

Test voltages: Wire/wire 1500 V, wire/shield 1200 V

5.1.4 Required tools (not in scope of delivery)

- Folding ruler
- 4mm (532/») Hex/Allen key screwdriver
- Hexagon socket screw driver 4 mm
- Small flat-tip screwdriver for electrical connections
- Flat-tip screwdriver 2 mm (pole assembly)
- Suitable screwdriver, shank length at least 180 mm (wall mount)
- Engineer's pliers
- Wire cutter (knife)

5.1.5 Required accessories (not in scope of delivery)

- Alignment telescope with PRO E adapters (CH18000101)
- iCommission (CH12003001)
- IFM-485-ST USB Interface Module (CH19000301)
- PRO E-IPM IP Module (CH12005001)

5.2 Pole mounting of detector holder

**CAUTION:**

Ensure that cables are neatly in place before tightening the clamps to avoid damage to cables through forcible pressing and buckling.

Due to the low net weight of ADPRO PRO E-detectors, mounting is designed to use standard hose clamps with a screw flight (not provided).

Follow the installation instructions below:

1. Break off the grooves for the screw clips from both panels as shown.



2. Insert both panels as shown. Lock the panels in place with an audible click.



3. Insert the rounded molding (marked in red here) into the detector arm as shown.

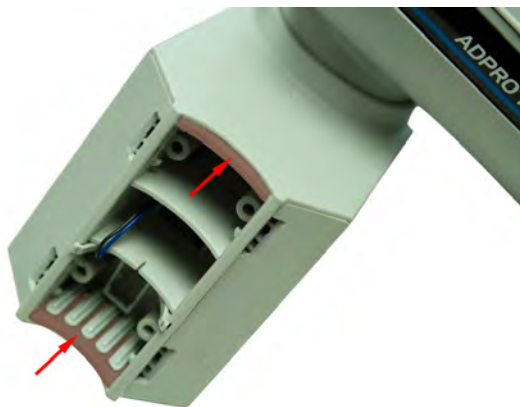

4. Choose screw clips of a suitable diameter depending on the pole.

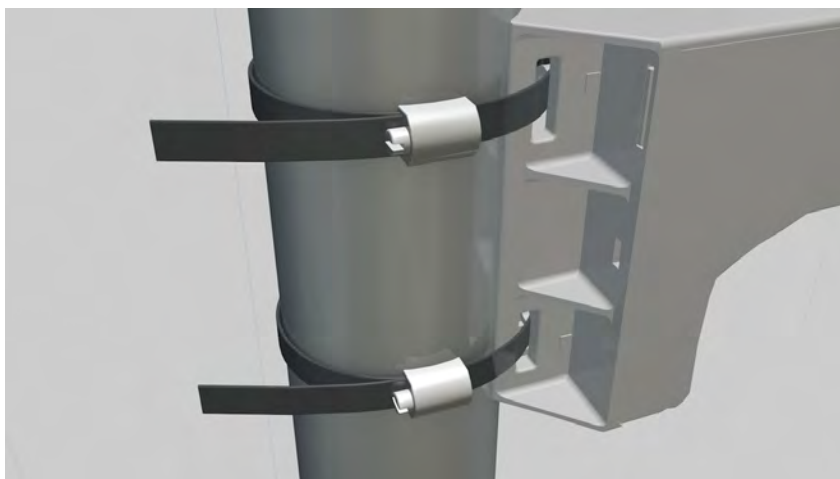

5. Guide the cables through the cable entry point in the detector arm casing.

Notes:

- At this time, align the detector arm approximately at the pole. The detector should be attached on the side of the pole to make subsequent alignment using the alignment telescope easier.
 - This can be configured accurately later at the time of commissioning without loosening the clips. (Installation of detector in detector holder Pg.33)
6. Carefully tighten the screw clips uniformly.

5.3 Wall installation of detector holder



Notes:

- Ensure that the wall is sufficiently sturdy. If you mount on thin and dry construction walls, use special hollow cavity plugs if necessary.
 - Use sufficiently long screws with an external diameter of at most 5 mm and a flat screw head.
1. Drill and dowel as shown on a suitable wall.

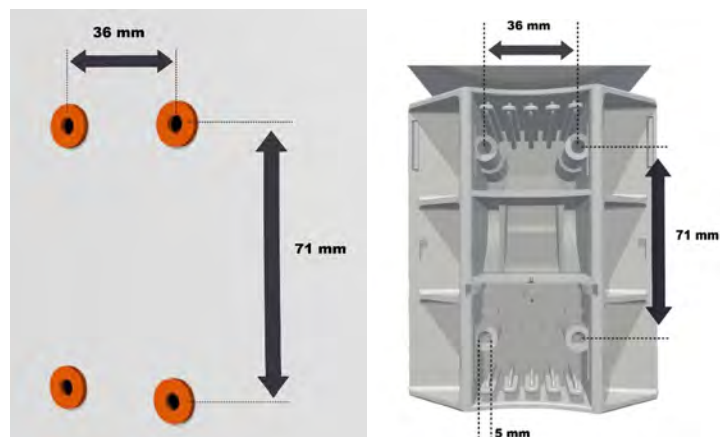

2. Insert the straight moulds (marked in red) as shown into the detector arm.

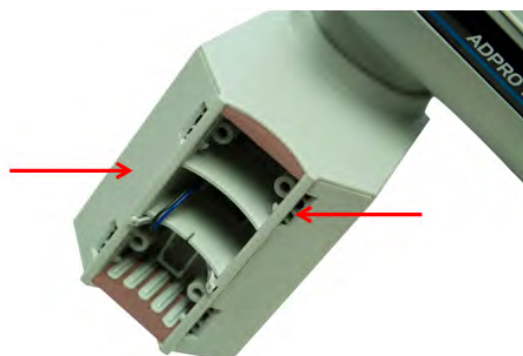

3. Screw in the detector arm as shown, using suitable screws. The upper screws should have a threaded length of a min. of 75 mm and the lower screws a min. of 60 mm.



5.4 Installation of detector in detector holder

1. Place the detector as shown and press it in lightly into the detector arm till it locks into place and the lateral notches are no longer visible.

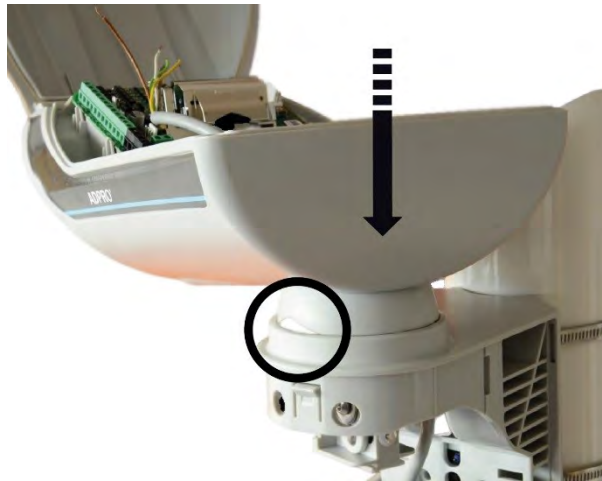

2. Insert the three hexagon socket screws supplied as shown and screw these in so that the detector does not wobble appreciably but can still move horizontally. Do not tighten!

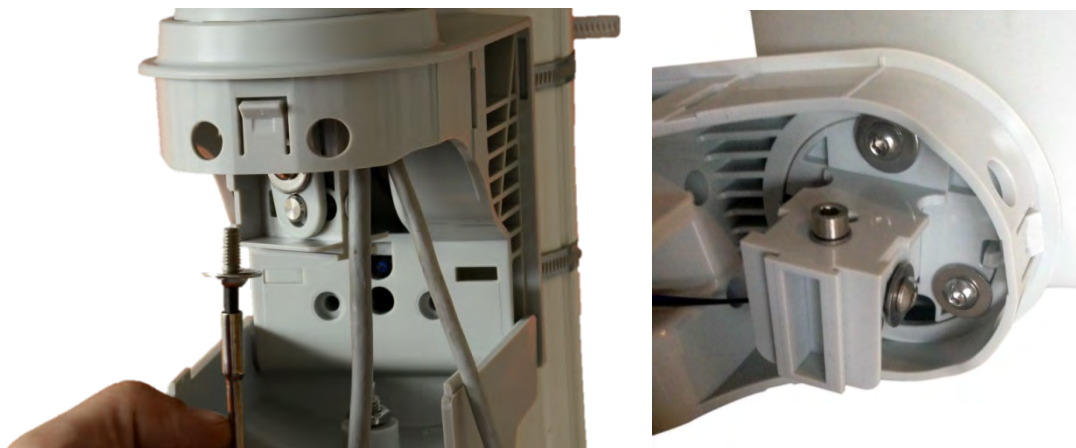

3. Align the detector horizontally carefully.



This page is intentionally left blank.

6 Installation

The following sections describe the connection and basic commissioning of PRO and PRO E detectors. Connecting PRO E-RF detectors is described in section "PRO EPRO E-RF installation steps".

6.1 Connect detector

In the design of the detector and integrated detector holder, great care was taken to see that cabling (cable management) could be installed very easily and quickly, and yet provide the highest level of tamper protection, a veritable boon for the installer. The centerpiece of the solution is a patented self-sealing kidney-shaped cable seal (Kidney Seal) which allows premanufactured cables with plugs to be used.

Both the cabling and the housing cover can be opened and closed easily using screwed plugs or click connectors.



CAUTION:

- To protect detectors from permanent damage due to potential differences, ensure that if AC voltage is supplied, all detectors are connected identically and L1 (+) and N (-) on the secondary-side are not interchanged.
- To eliminate confusion and make your work easier, we recommend the use of colored or coded cables – even if AC voltage is used.

Proceed as follows when connecting a detector:

1. Remove the cable insulation on the terminal side by approximately 3 mm.
2. Open the detector arm as shown.

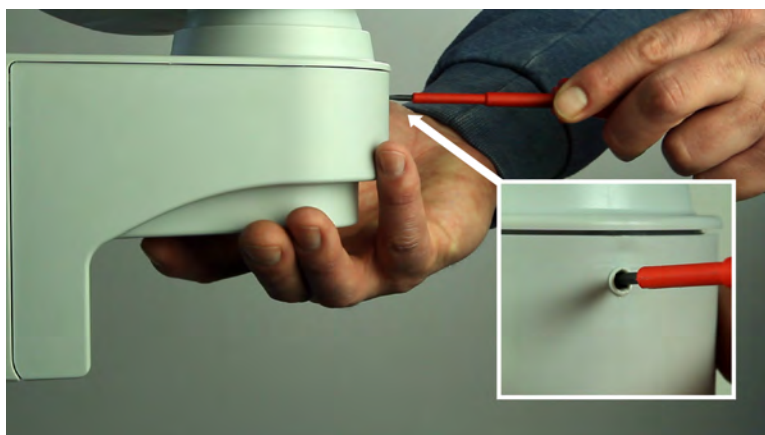

3. Open the housing cover by unscrewing both housing screws.



4. If you are using an optional IP module (part number: CH12005001) in your detector, install the IP module as described in chapter "PRO E-IPM (IP module)".
5. Remove the cable seal so that all cables can be fed without problem through the channel.

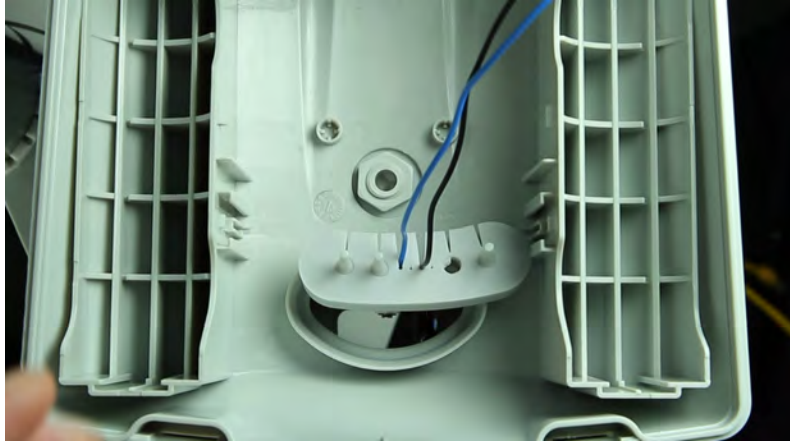

6. Feed all cables from underneath through the channel into the detector housing.



7. Check the number and diameter of all cables used.
8. For cables of larger diameters, remove material from the patented cable seal with a knife at the spots provided if necessary.

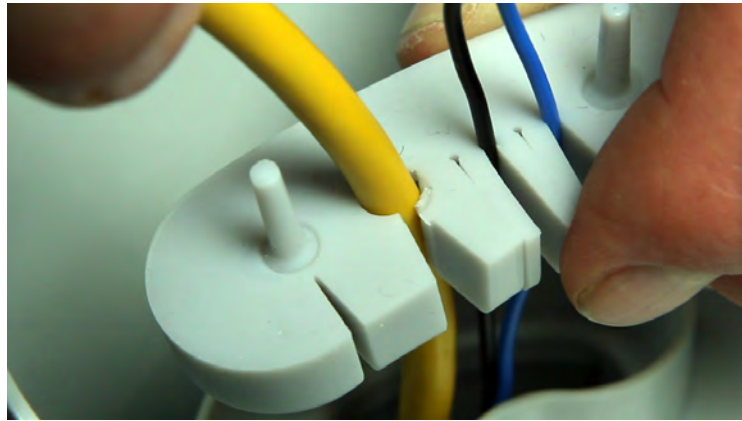

9. Feed all cables through the seal as shown, based on their diameter.

**CAUTION:**

If you have erroneously removed one groove too many from the cable seal, close it with a piece of cable remnant of appropriate diameter to maintain IP 65 rating.

10. Now insert the cable seal with the cables fixed in it into the housing so that it interlocks as shown. Check that the seal is seated correctly with a positive fit.

**Power Supply****CAUTION:**

- It is recommended to use an EN50131-6 compliant power supply.
- The minimum voltage at the detector should not fall below 11.7 VDC in any operating condition.
- For PRO E-detectors of version "H", heating power consumption must be considered when defining the main power supply.



11. Connect the power supply and bus cable as shown, the red Front LED blinks slowly to indicate that the power supply is connected, as long as the cover is open.

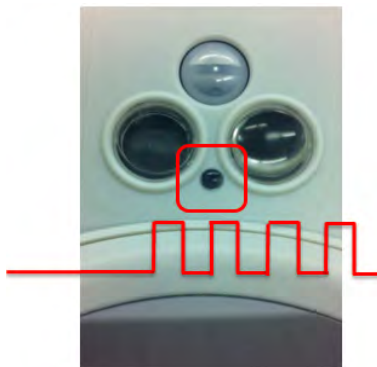

12. Close the housing cover, torque 0.5 Nm.



Closing the cover activates the Test mode. The red front LED stops blinking and flashes during alarms.

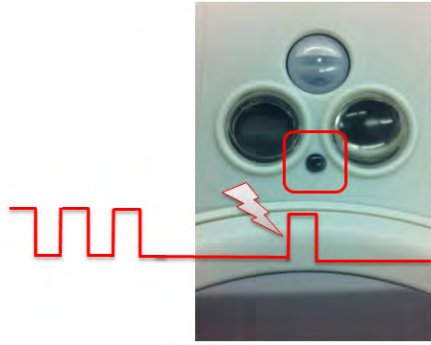

13. Align the detector (see "Alignment with the help of the telescope" on page 65), adjust the settings using the PRO software (see the ADPRO PRO E PIR System Setup Guide, document no. 26571, Use of ADPRO PRO E-Tool Software section) and confirm through walk tests.
14. Close the detector bracket.



Once the performance of the detector is satisfactory, close the bracket to start operation. Properly closed, the flap clicks in with an audible click. The red front LED blinks quickly until position and sensor readings are final. If the LED does not start blinking, please refer to "Fine adjustment of tamper switch" on page 41.

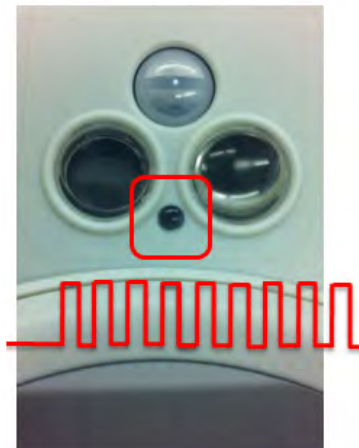

After 30-60 seconds all sensors have finalised their internal setup and are active. The front LED is permanently deactivated and the detector is fully operational.

6.2 Fine adjustment of tamper switch

Note: If everything is correctly wired and no component of the tamper protection mechanism reports tamper, the LED in the detector starts to blink for approximately one minute. There are tamper switches both in the detector housing as well as in the cable routing. Before configuring the rear tamper switch, therefore, make sure that the housing and cabling are correctly closed as described above.

All ADPRO PRO E detectors are equipped with a tamper switch in series, which detects any attempt to remove the detector from its mounting point (pole or wall) in compliance with standards.

This switch must be configured such that even a minor loosening of a screw triggers a tamper alarm. The rear tamper switch must therefore be mounted on the surface finish of the pole or wall if possible.

Configuring the rear tamper switch:

1. Check to see if the detector housing is properly closed.



2. Rotate the lower hexagon socket screw into the detector arm as shown until the tamper switch opens as provided and the LED starts to blink.



3. Turn the screw another two or three rotations. The LED should continue to blink.

6.3 Connect detectors to IFM-485-ST

Up to 128 detectors can be connected to an IFM-485-ST for configuration and monitoring:



WARNING:

- The device must not be used in potentially explosive areas, or areas where work with hazardous substances is being carried out.
- Observe the safety notes in the IFM-485-ST Quick Installation Guide (document no. 27178).



CAUTION:

- If the IFM-485-ST as well as all PIR detectors are supplied with AC voltage, it is absolutely necessary to ensure that all detectors and the IFM are connected identically and L1 (+) and N (-) are not interchanged. Otherwise, there could be substantial damage to detectors other than the detector with reversed polarity due to overheating as soon as the RS-485 bus and its ground (earth) are connected.
- This would be due to the formation of a potential difference of 24VAC between the grounds (earth) of two PIR detectors. See diagram below.
- To eliminate confusion and make your work easier, we highly recommend the use of coloured or coded cables – particularly if AC voltage is used.
- To prevent malfunction or destruction of equipment caused by potential differences, make sure that GND is always connected between all detectors and interface module IFM-485-ST.
- Do not use the RJ12 test cable on any powered detectors.
- Please mind polarity of the power lines, even if AC powered and make sure the detectors get 11VDC minimum.

Notes:

- Ensure that the total cable length (including tap holes) does not exceed 1000 m.
- Please ensure that you have the latest version of the drivers and the ADPRO PRO PIR Tool Setup Software_Vx.xx installed on your PC at all times.

Perform the following steps to connect more than one detector to a PC via the RS485 data bus:

1. Connect the detectors in parallel.
2. Add a terminating resistor of 120 Ω between the RS485 and RS485 B connections on the circuit board of the last detector in the bus. The (switched) resistor is already built into the interface module IFM-485-ST. This properly terminates the data connection to both ends of the bus.

The following illustrations show a schematic overview of the interconnection.

Permitted Connection Diagram – Operation with HeiTel CamDisc(+) E / ipVG Series:

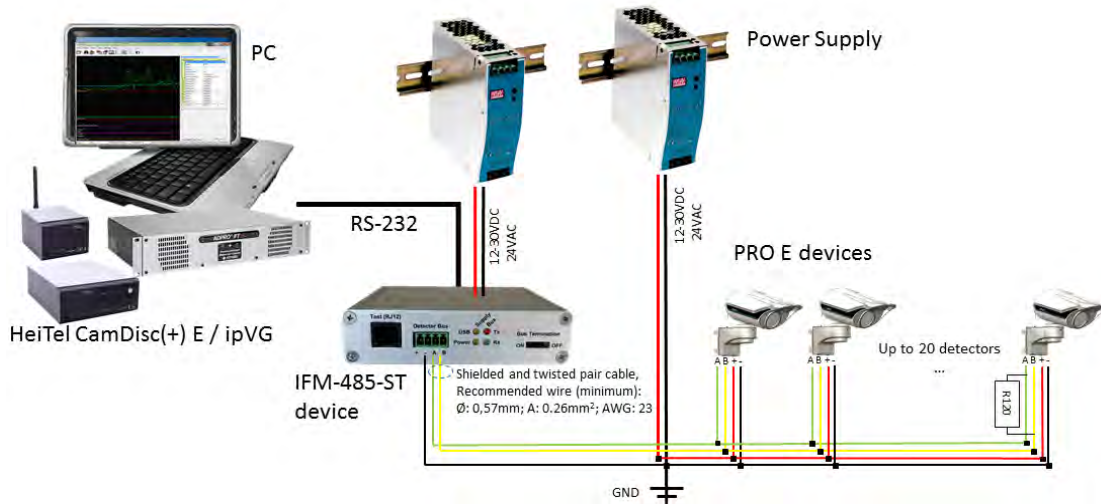

Permitted Connection Diagram – Operation with FastTrace / iFT / iFT E Series:

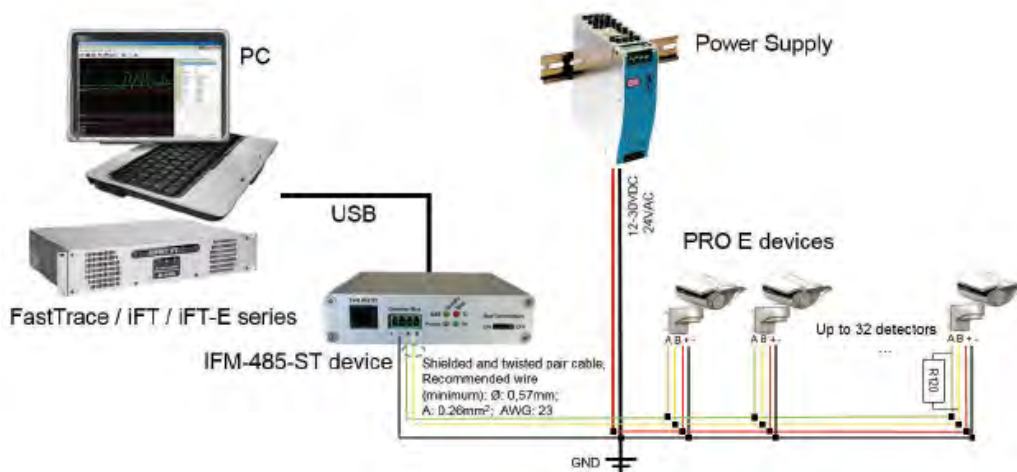

6.4 Final check of the basic installation

Check the basic functioning of the detector after installation. This will ensure that all interface connections have been correctly installed and that the basic alignment is suitable. The goal is not final fine-tuning of the detector at this point but to test its basic functioning so that subsequent straightforward commissioning of the detection system is possible.

Note: Do not align the detector in a way that it directly points towards a wire fence. Also, there should be no objects that are likely to be moved by the wind (such as branches, shrubs, fences) or waters in the detection range.

The detection range of a PIR detector is not limited but a function of size, speed and temperature contrast of a target against its background. The detector should be aligned so that a natural or artificial background at the end of the range terminates the field of view. Optimum vertical alignment is achieved when the upper edge of the field of view is at 2 m above ground at the end of the nominal detection range.

For nominal detection ranges refer to the document "ADPRO PRO E PIR System Design and Planning Guide, document no. (27387)".

Check the installation as follows:

1. Make sure that unique individual addresses (2-255) are assigned to all detectors, see "Connect detectors to IFM-485-ST".

2. Start the ADPRO PRO E-Tool.
 3. Select detector:
Options, Search Detector or press [F3]. The search dialogue is displayed
 4. Click **Start**.
You can cancel the ongoing search process by clicking **ESC**.
In the **Search list** shows the detectors found. Check to see if all detectors connected are found.
 5. Double-click on the desired item in the list, or enter the detector address (in the example above 1) in the **Detector** field and click **OK**.
The signals of the selected detector are displayed in the ADPRO PRO E-Tool.
You can use the ADPRO PRO E-Tool for further configuration of the detector.
For details on the ADPRO PRO E-Tool refer to the ADPRO PRO E PIR System Setup Guide, document no. 26571.
- Note:** Make sure the latest firmware is installed on all detectors. The currently installed version is displayed in ADPRO PRO E-Tool as Version parameter. You can download the latest firmware from the Xtralis partner portal www.xtralissecurity.com, doc. no. 29461). The firmware update is described in section "Firmware update (ADPRO flashloader)".
6. Check the general functioning and check if alarms are triggered.
 7. Repeat the connection process to check all detectors in the installation.
- In case of problems refer to chapter "Troubleshooting".

6.5 PRO E-RF installation steps



WARNING:

The device must not be used in potentially explosive areas, or areas where work with hazardous substances is being carried out. Intrinsically safe models are available (IS family of products).

PRO E-RF detectors use the PRO E-IFM-RF as a custom data interface instead of standard RS-485 in order to reduce power consumption.

Note:

- Once connected to the PC, installation, drivers and use are the same as with the RS-485 interface (IFM-485-ST). Refer to Connect detectors to IFM-485-ST".

PRO software (Version 9.27 and up) fully supports PRO E wireless detectors, once connected via PRO E-IFM-RF module.

All sensors, thresholds and alarm channels appear in real time as shown below:

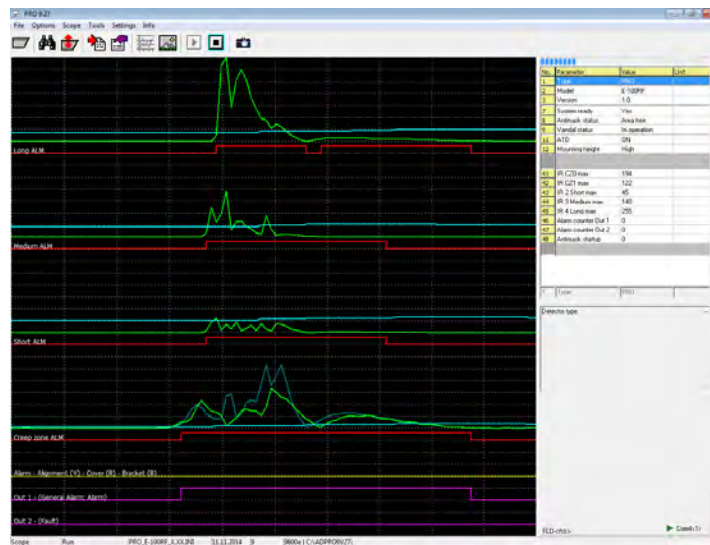

All settings are identical to the standard PRO E detector, but reflect PRO E-RF features (only one output, no proximity switch to reset in cover to reset).

When using SW settings, make sure that DIP switch 1 & 2 are off (default).

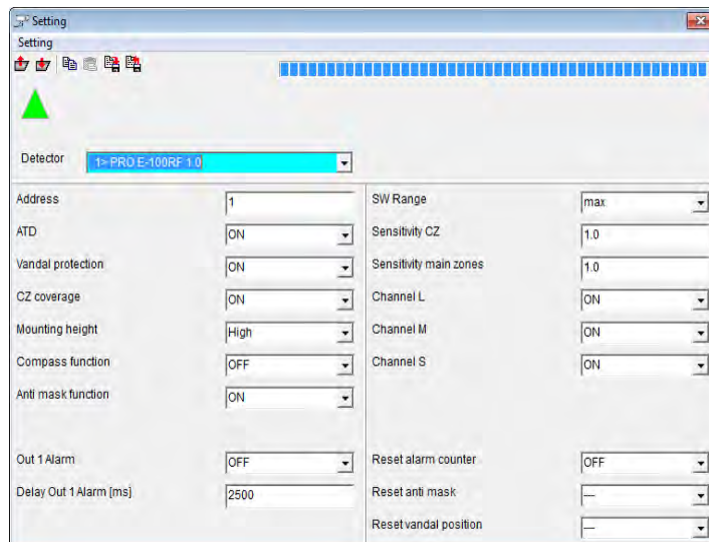

The same steps are used for commissioning both standard and wireless PRO E detectors. However, there are some differences as mentioned below:

- DIP switches
- Connecting the RF transmitter to the receiving panel
- Custom data interface
- Final commissioning procedure

Please refer to the PRO E guide for site layout, mounting, alignment, software settings, etc. see the ADPRO PRO E PIR System Setup Guide, document no. 26571, Use of ADPRO PRO E-Tool Software section).

As with the standard detectors, it is always recommended to use the SW interface for fine tuning, but since the specific RF interface might not be always at hand, DIP switches can be used as well:

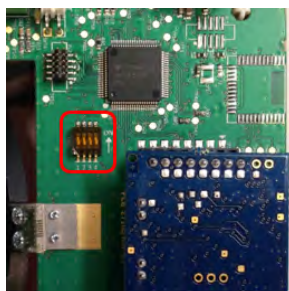

DIP 2	DIP 1	Function
off	off	SW-Mode/ Sensitivity according to SW settings (default: 100%)
off	on	HW-Mode/ Sensitivity 60%
on	off	HW-Mode/ Sensitivity 80%
on	on	HW-Mode/ Sensitivity 120%

DIP 3: ATD on/off (if DIP 1&2 are set to a HW mode setting)

DIP 4: Pulse count on/off for PRO E-18WRF; (if DIP 1&2 are set to a HW mode setting)

6.5.1 Overview PRO E-RF PCB

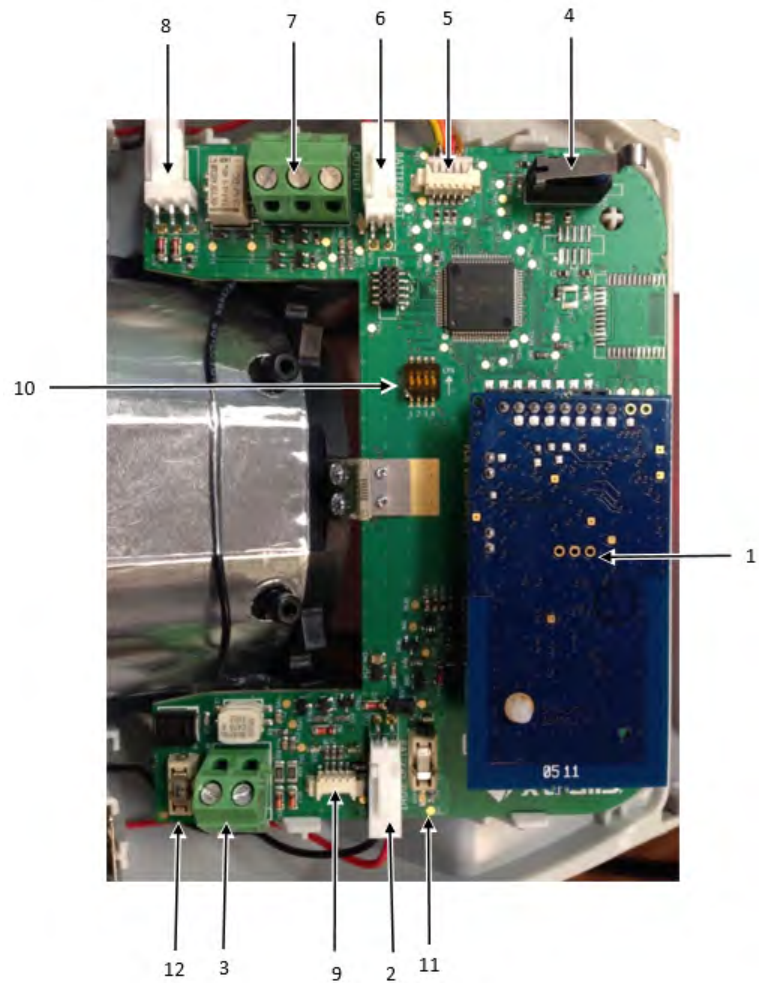

- 1 Inovonics wireless transmitter module, plugged in PCB
- 2 Right battery pack connector
- 3 External power source terminal
- 4 Cover tamper switch
- 5 RF Interface module connector (power/bus)
- 6 Left battery pack connector
- 7 Alarm relay terminal (NO/C/NC)
- 8 Bracket tamper switch connector
- 9 Power module connector
- 10 DIP switches
- 11 Battery power fuse
- 12 External power source fuse

6.5.2 Installation steps for PRO E-RF detectors

To install PRO E-RF detector, follow these steps:

1. Mount the detector,
2. Make sure that the bracket switch is connected (SKT5), and the bracket hatch is open,

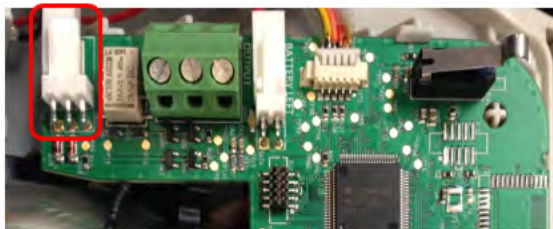

3. Insert batteries. For reasons of better temperature stability we recommend 3.6V Lithium. However, 1.5V Alkaline are also possible. Connect to circuit board. Also, connect the external power source (if available). The external power source must be between 8.5 and 28 VDC. Any higher voltage could cause permanent and irreversible damage.

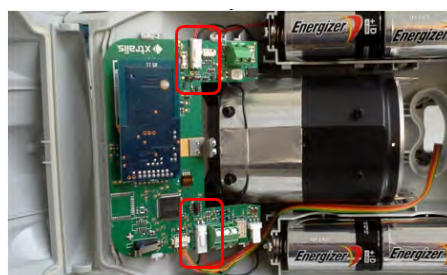

The device starts up.

As long as cover is open, the red LED blinks slowly.

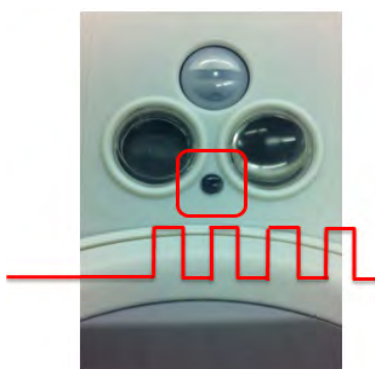

4. Start the Test mode:
 - a. Close cover, tighten screws, leave bracket open. You will notice the following:
 - Red LED stops blinking
 - Device enters walk test mode
 - Alarms are indicated by the red LED
 - While in test mode, the detector wirelessly transmits alarm channel 1 during alarms to indicate alarms at the alarm panel and constantly sets alarm channel 2 to indicate being in Test mode.

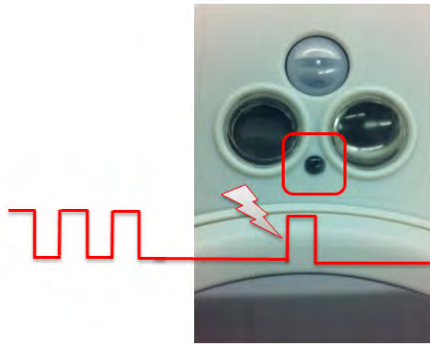

- b. Go through setup:
Alignment, walk tests, software settings, fine tuning alignment.

When the performance is satisfactory, close the bracket.



Front LED will start blinking fast.

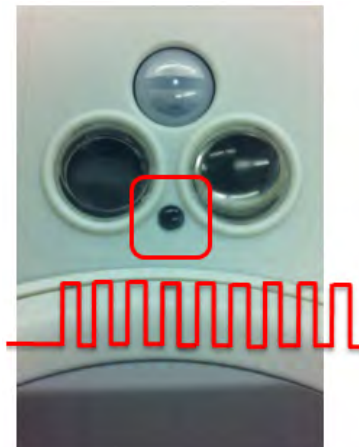

If LED does not start blinking, make sure the tamper switch in bracket is closed by turning front screw until LED does start blinking.



Make sure the detector has an unobstructed view below and around it.

After 30-60 seconds, internal settings are done and the front LED will be permanently deactivated.

The detector now starts operating and you will notice the following:

- Alarms in the main and creep zone zones will be transmitted as Alarm 1
- Fault/low batteries will be transmitted as Alarm 2
- All tamper and vandal alarms (cover, bracket, alignment, anti-masking) are transmitted as Tamper
- A "heart beat" signal is transmitted to show that the unit is still operational. For (RFn) models the signal is transmitted every 3 minutes and for RFe models every 12 minutes.

Inovonics Receivers

The included Inovonics Receivers can send alarms to all compatible panels, see

<http://www.inovonics.com/products/add-on-receivers/>

and

<http://www.inovonics.com/products/serial-receivers/>

Please register the detector PRO E-RF transmitters at the receiving panels according to the respective Inovonics manual (section "setup point") with the following details:

- Set supervision time (SPV) to 60 minutes
- Register the transmitter as "Security" device (not "repeater")
- Make sure, that the transmitter is registered as 2-alarm-inputs device
- Set the alarm output type to "follower"
- Outputs are matched with the following events:
 - Alarm 1: Intruder in main zone or creep zone (360PROtect)
 - Alarm 2: low battery
 - Tamper: any tamper alarm
 - Low power: unused inovonics feature, do not assign any outputs to this function
 - Inactivity: triggered when panel receives no alarm or heart beat signal for the set SPV (60 minutes)

This page is intentionally left blank.

7 PRO E-IPM (IP module)



WARNING:

The device must not be used in potentially explosive areas, or areas where work with hazardous substances is being carried out.

PRO E detectors use the RS-485 bus for remote maintenance and alarm management. The IP module (IPM) converts this RS-485 bus to Ethernet and makes it available remotely via the IP address of the module.

This chapter describes installation, configuration, and usage of an IP module in an ADPRO PRO E detector. In the described scenario network connection to a PC and power supply (PoE) are provided by a network switch. For the RS-485 connection purpose a virtual COM port (VCP) is set up.

Note: The descriptions in this chapter refer to recommended practices with example values which may be different in your application. However, such alternatives are not described, at least not in detail.

7.1 System overview

In order to be able to use an IP module you need

- ADPRO PRO E detector
- IP module (art. no. CH12005001)
- Network cable
- Network switch with PoE connection

Note: If no PoE connection is available it is also possible to use a Y cable adapter (injector) for power supply.

The following illustration shows an overview:

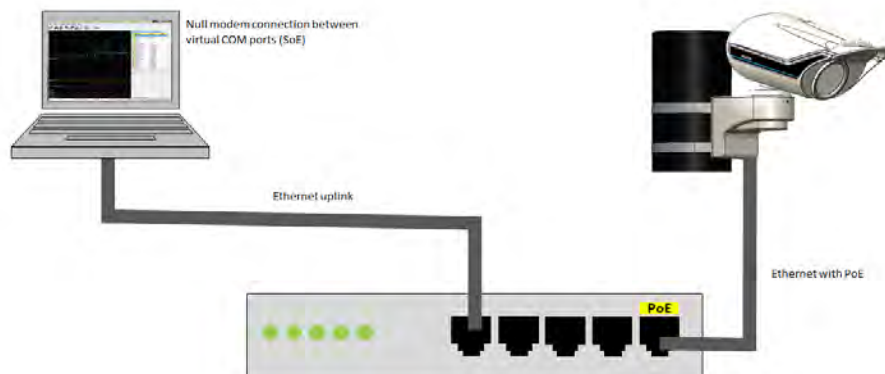

Power supply of the detector is provided by the Ethernet connection (PoE). Data are transferred via a virtual COM port connection (serial over Ethernet, SoE) which is set up on the configuration PC.

7.2 Install IP module

7.2.1 Mount IP module

Proceed as follows when mounting the module:

1. If required, open detector arm and housing, remove the cable seal, see "Connect detector".
2. Carefully insert the IP module as shown in the image below, and gently push it into the slot, until it locks as shown.

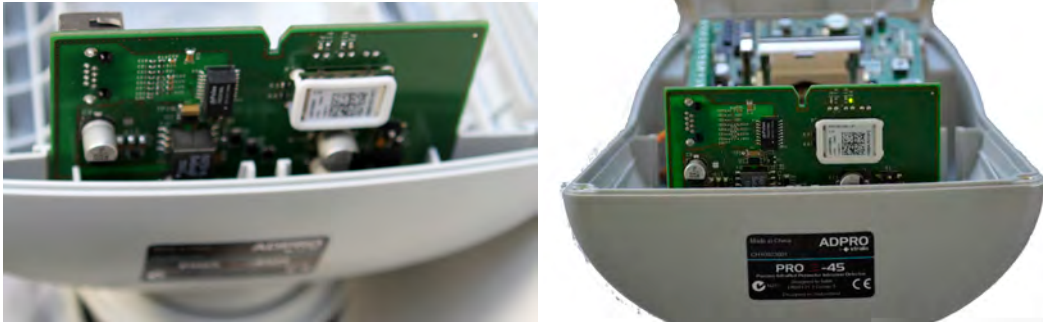

3. Feed the network cable from underneath through the channel into the detector housing.



4. Use the cable kit supplied to connect the IP module to the detector's circuit board. For pin assignment refer to "Overview of the circuit board".
Connect the Molex connector of the cable kit to the connector on the IP module's circuit board.

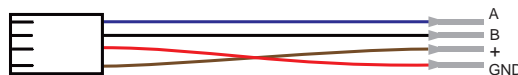
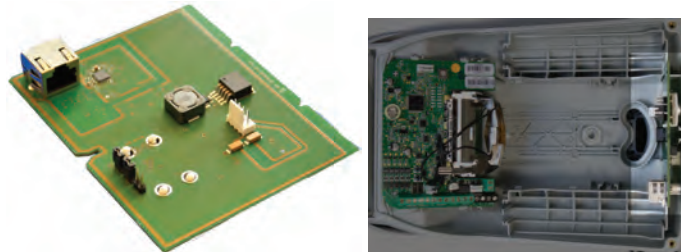

5. Connect the loose cable ends to the terminals on the circuit board:
Blue to terminal A
Black to terminal B
Brown to +
Red to ground(GND)
6. Connect the network cable to the RJ45 connector of the IP module (data and PoE).
7. Fit all cables in the cable seal and insert the cable seal. Refer to "Connect detector".
8. Close the housing and the detector arm.

7.2.2 Connect detector

Proceed as follows to physically connect the detector to the network:

1. Connect the detector to a PoE output on the network switch.
Note: If no PoE connection is available it is also possible to use a Y cable adapter (injector) for power supply.
2. Connect the network card of the configuration PC to the network switch (uplink).
3. Switch on the network switch and wait until the detector start-up is completed.

7.3 Setup IP module

7.3.1 Preparations

For installation and operation of the IP module you need the following software:

- Lantronix DeviceInstaller
Download from http://itxfaq.custhelp.com/app/answers/detail/a_id/644 or from the Lantronix web pages: <http://www.lantronix.com>). The software serves for installation and configuration of the IP module.
- Tools for configuration of virtual COM port connections (null modem emulator).
We recommend the free tools com2com and com2tcp. The following descriptions refer to these tools.
Download from <https://sourceforge.net/>.
- ADPRO PRO E-Tool
See System Setup Manual (doc. no. 26571).

Install the software before you proceed.

7.3.2 LAN connection

Note: The data and details used, particularly in case of IP addresses are examples which may be different in your application.

IP module and configuration PC must be in the same network. If required, set up the network card of the configuration PC to the network in which the IP is located:

1. Select Control Panel, Network and Sharing Center.
2. Open the status dialogue by clicking the LAN connection of the related network card.
3. Click **Properties**. The Local Area Connection Properties dialogue is displayed.
4. Select the **Internet Protocol Version 4** item and click **Properties**.
5. If required change the details of the network connection in the Internet Protocol Version 4 **Properties** dialogue in a way that IP module and the connected PC are in the same network:

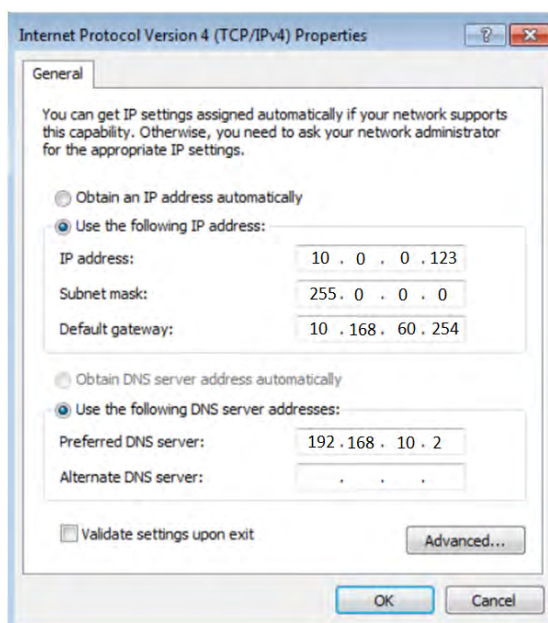

6. Confirm all dialogues.

7.3.3 Setup in DeviceInstaller

Note: It is important that you adhere to the sequence of the following steps. Otherwise the connection might fail.

Use the Lantronix DeviceInstaller to check the IP connection to the IP module and to adjust required settings:

1. Start the DeviceInstaller.
You might be prompted to select a network adapter if more than one adapter is available.
2. The DeviceInstaller automatically looks for devices in the network.
To look up devices manually press [F5].

Note: If the network on which the IP module is located cannot be accessed directly, you can use the Assign IP button to switch the IP module to a different IP address. In case this fails, try connecting the PC and IP module via a standalone network switch without connection to other networks and set the PC's network settings according to the existing network configured in the IP module.

Assign IP:

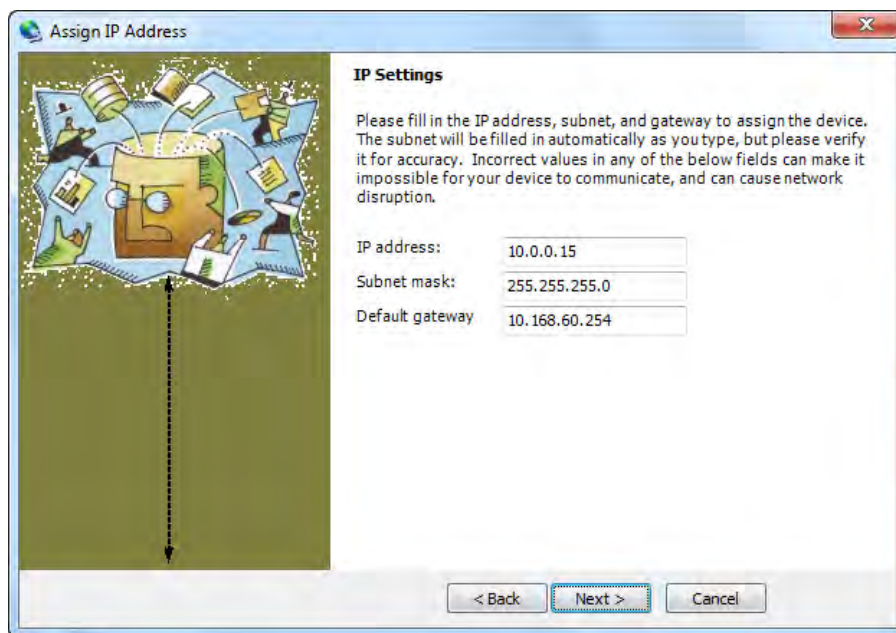

3. Always make sure that the network details in this dialogue match the details of the configuration PC (see above). Click **Next**, **Assign**, and then **Finish**.
4. In the DeviceInstaller select the **Web Configuration** tab.
Alternatively you can select the device address using a different web browser.

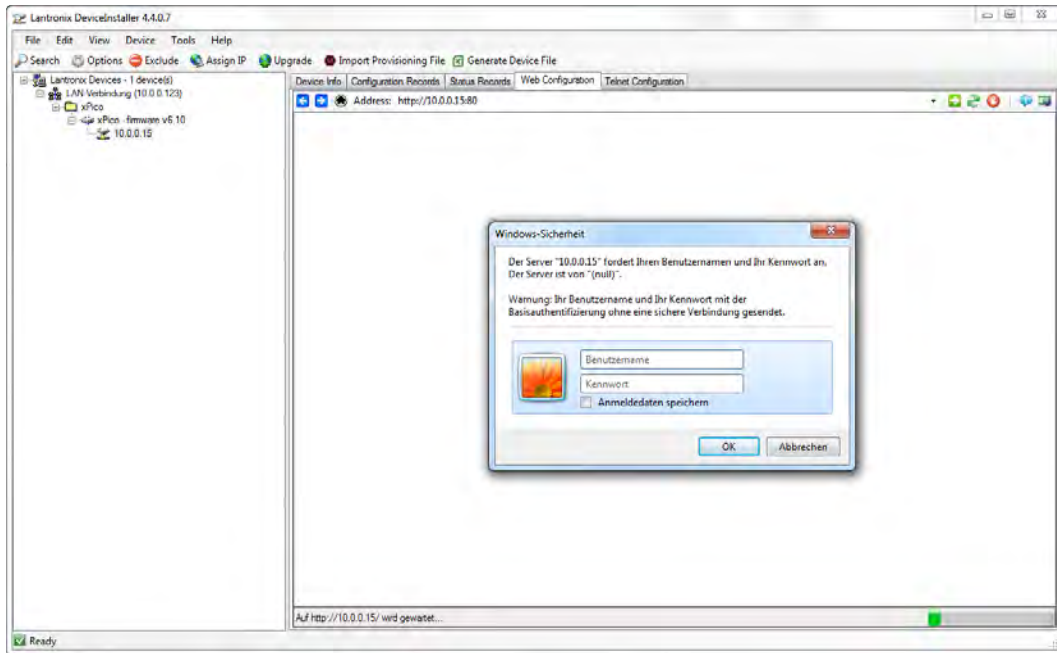

5. In the Windows security leave the **User name** and **Password** field empty and click **OK**.
6. Under **Channel 1, Serial Settings** adjust the following settings:
Port Settings: RS485 – 2 wire
Parity: Even

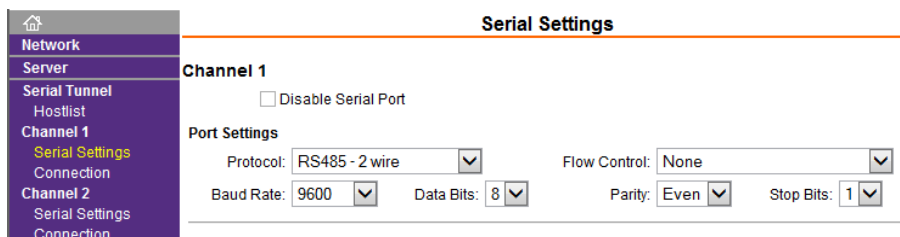

7. Click **OK** to save the settings locally.
Note: This will not yet upload the settings to the IP module. This is done in the last step, see below.
8. Under **Channel 1, Connection** adjust the following values:
Protocol: UDP
Datagram Type: 01

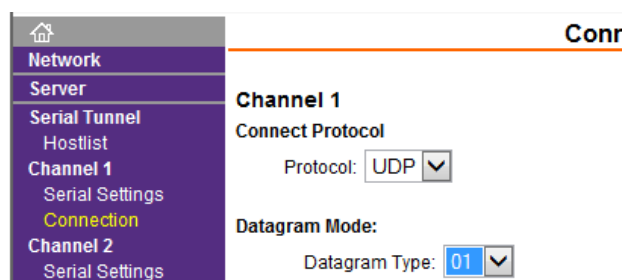

9. Click **OK** to save the settings locally.
10. Under **Network** configure the network settings of the IP module.
 If the detector is in the same network as the related control unit (e.g. the PC running the ADPRO PRO E-Tool), enter a Gateway IP of "0.0.0.0" to prevent routing of packages from the detector.

- Click **Apply Settings**. The settings are now transferred to the IP module.

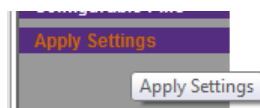

- Adjust the connection mode:
Select the IP module in the DeviceInstaller and select the **Telnet Configuration** tab.

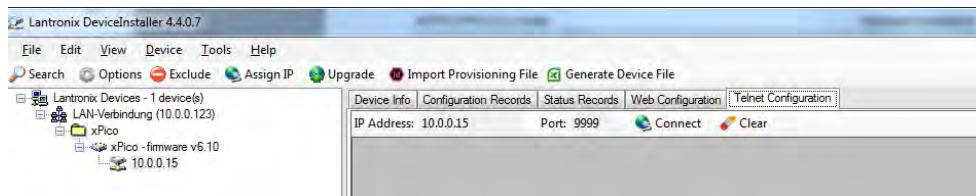

- Click **Connect**.
- Press Enter within the first 5 seconds after connecting to enter the device setup mode. If the Enter key is not pressed within 5 seconds after successfully established connection, then the telnet-Server of the IP module will disconnect. The connection then has to be re-established.
- Select 1 to change the settings of Channel 1.
- Press Enter (keep standard settings) until you reach ConnectMode.
- Enter "C0" ('C' and 'null') and press Enter.
- Press Enter until you reach the main menu again.
- To save the settings and to terminate the Telnet configuration select 9 (Save and exit).

The settings are stored in the module. You may close the DeviceInstaller. As soon as the data have been transferred to the IP module the detector can be accessed via Serial-over-Ethernet connection (SoE).

7.3.4 Setup virtual COM ports (com0com and com2tcp)

Establish a RS-485 connection to the IP module using virtual COM ports:

- Start com2com software installation.
- Under **Select components to install** select all options except the last one (COM# <-> COM#):

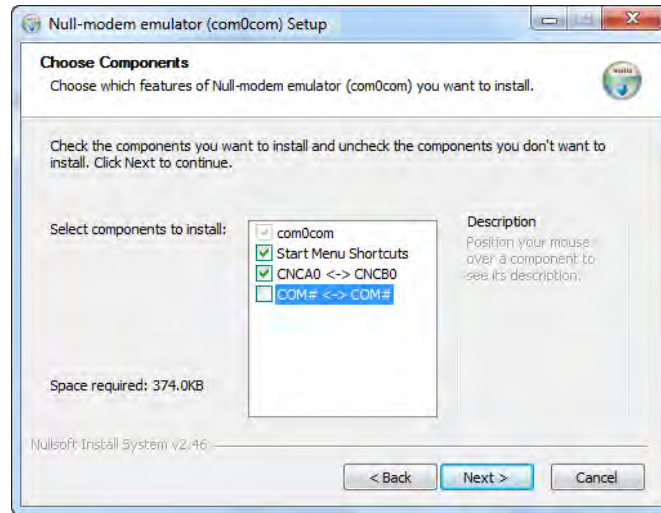

3. Click **Next**.

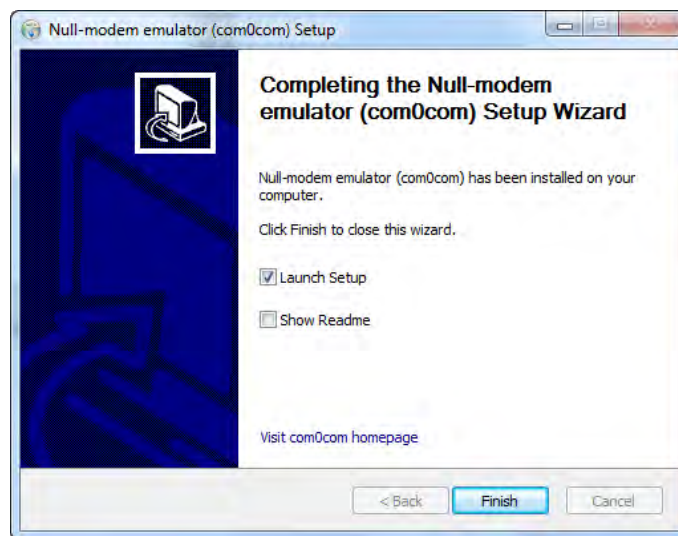

4. At the end of the installation select the **Launch Setup** option and click **Finish**. The Setup window is displayed.
5. Enter designations for the two ports, which are not assigned on the PC. Port numbers which are already assigned are displayed in red.

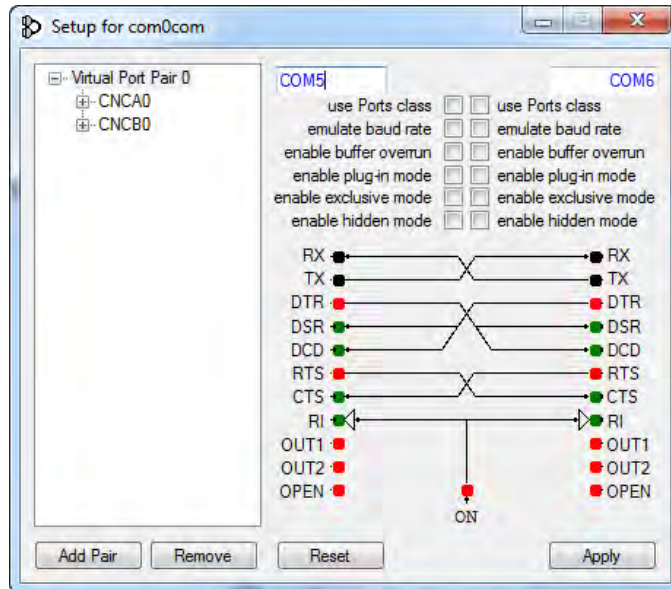

6. Click **Apply**.
7. In the Windows Control Panel open the Device Manager.
The virtual port you have configured must be displayed in the Device Manager.

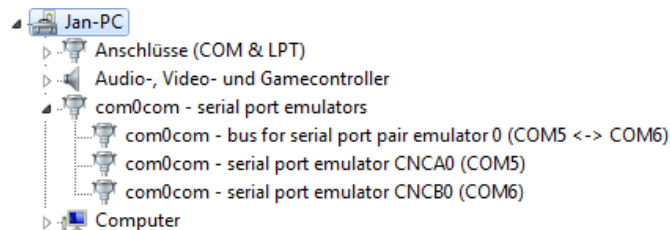

8. Unpack the com2tcp software.
9. In the program directory of the com2tcp software create batch file with the following contents:

```
start com2tcp --ignore-dsr --baud 9600 \\.\COM6 10.0.0.15 10001
```

If you use different parameters (e.g. different IP address or port number) these must be adapted in the batch file accordingly.

10. Save the batch file as text file and assign a meaningful name, e.g. "start_com2tcp_for_15_on_COM6.bat."
11. Start the batch file by double-clicking it in the Windows Explorer. The Windows console is displayed in a terminal window.

Note: This window must remain open as long as the connection is active! Otherwise it is not possible to access the IP module via the serial connection.

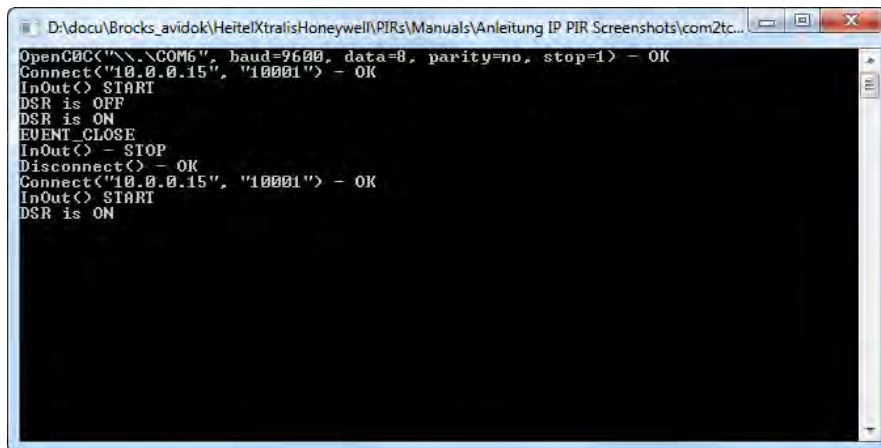

```

D:\docu\Brocks_avidok\Heite\XtralisHoneywell\PIRs\Manuals\Anleitung IP PIR Screenshots\com2tc...
OpenCOM6 << "\\.\COM6", baud=9600, data=8, parity=no, stop=1>> - OK
Connect("<!--"10.0.0.15", "10001") - OK
InOut() START
DSR is OFF
DSR is ON
EVENT_CLOSE
InOut() - STOP
Disconnect() - OK
Connect("<!--"10.0.0.15", "10001") - OK
InOut() START
DSR is ON

```

12. Start the ADPRO PRO E-Tool.
13. Select **Options, Com Port**.
The COM ports previously created are displayed in the list of available ports.
14. Select the COM port of the pair, which is **not** specified in the above batch file (in the example COM5).

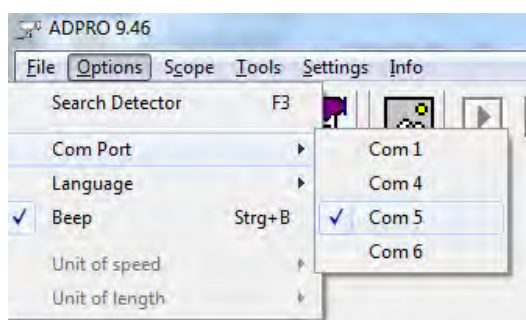

15. Select **Options, Search detector** (or [F3]) and start the search process.
16. Double-click the entry of the detector in the Search list.
The detector signals are displayed in the scope panel.
For more details refer to the System Setup Manual (doc. no. 26571).

7.3.5 Shut down connection

To terminate the connection to the detector, proceed as follows:

1. Close the ADPRO PRO E-Tool.
2. Close the terminal window (Windows console).
3. Switch of the network switch so that the PoE connection stops supplying voltage to the detector.

The connections are deactivated, and the detector is shut down.

7.3.6 Re-connect

Even after successful installation the null modem connection to the IP module must be reactivated after any down time or other interruption, e.g. if the terminal window with the com2tcp process was closed or if the connected PC was shut down. Proceed as follows:

1. Start com2tcp via the batch file.
The Windows console is displayed in a terminal window.
Note: This window must remain open as long as the connection is active! Otherwise it is not possible to access the IP module via the serial connection.
2. Start the ADPRO PRO E-Tool.
3. Select **Options, Com Port** and then select the COM port of the pair, which is **not** specified in the above batch file.
4. Select **Options, Search detector** (or [F3]) and start the search process.
5. Double-click the entry of the detector in the Search list.
The detector signals are displayed in the scope panel.
For more details refer to the System Setup Manual (doc. no. 26571).

7.4 Connect multiple IP modules

If multiple detectors, which are all equipped with an IP module, shall be connected to the same workstation then additional ports must be set up using the com0com software because each detector requires a separate pair of virtual COM ports for the connection. For example, in a scenario with 3 detectors you need 3 pairs of ports:

1. Carry out the setup as described above under "Setup virtual COM ports (com0com and com2tcp)" and in the final step open the Setup dialogue (Option Launch Setup).
2. Set up the first pair as described above.
3. To add another pair of ports click **Add Pair**.
4. Assign the COM port designations and click **Apply**.

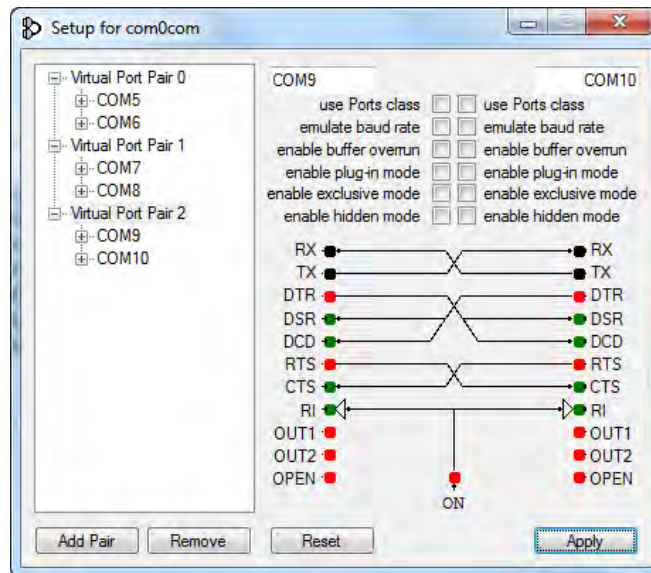

5. In the Windows Device Manager check the ports you have set up.

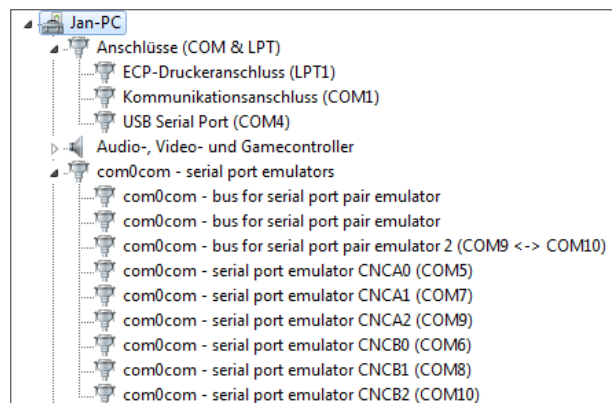

6. Close the Setup dialogue.
7. Create a script as shown in the example below and store it as text file with a meaningful name (file name extension .vbs):

```
Dim WinScriptHost
Set WinScriptHost = CreateObject ("WScript.Shell")
WinScriptHost.Run "com2tcp --ignore-dsr --baud 9600 \\.\COM6 10.0.0.15 10001", 0
WinScriptHost.Run "com2tcp --ignore-dsr --baud 9600 \\.\COM8 10.0.0.16 10001", 0
WinScriptHost.Run "com2tcp --ignore-dsr --baud 9600 \\.\COM10 10.0.0.17 10001", 0
If Err <> 0 Then
    MsgBox "Error! At least on connection could not be startet!",48,"PoE / SoE Starter"
Else
    MsgBox "All com2tcp connections started!",0,"PoE / SoE Starter"
End If
Set WinScriptHost = Nothing
```

8. Start the script, e.g. by double-clicking the file in the Windows Explorer, and confirm any security prompts.
9. Start the ADPRO PRO E-Tool.
10. Select **Options, Com Port**.
The previously created COM ports are shown in the list of available ports.
11. Select the COM port of the pair, which is **not** specified in the above script file (e.g. in the above example COM5 for the detector using the first pair).
12. Select **Options, Search detector** (or [F3]) and start the search process.
13. Double-click the entry of the detector in the Search list.
The detector signals are displayed in the scope panel.
For more details refer to the System Setup Manual (doc. no. 26571).

7.5 Connect multiple detectors to one IP module

If multiple detectors shall be connected to one IP module, then the additional detectors must be connected to the detector (the one with the IP module) via RS-485 bus as shown in the schematic illustration below.

Note: All detectors connected must have a unique address, which might have to be set up before mounting. Refer to “Before mounting – detector address and basic configuration”.

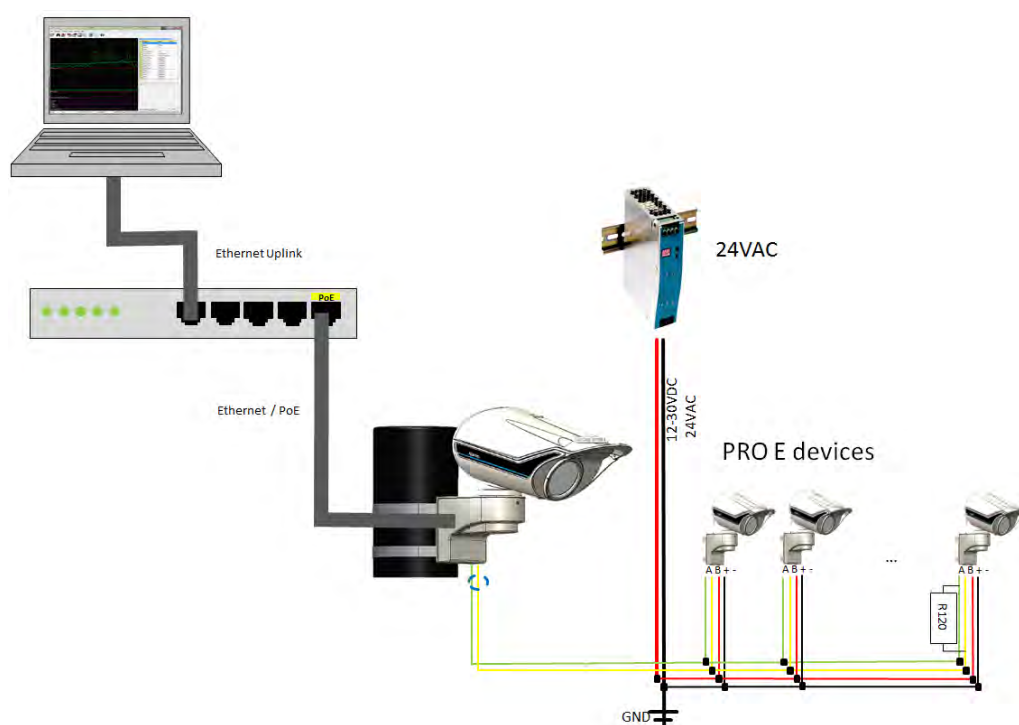

Proceed as follows:

1. Install and configure the IP module as described above under “Setup IP module”.
2. Shut down the detector as described under Shut down connection and terminate the connections.
3. Connect RS485-A and RS485-B on the circuit board of the detector with the IP module to the RS-485 bus.
4. Connect additional detectors. Connect terminals RS485-A and RS485-B of the circuit board of the respective detector to the RS-485 bus.
5. Add a terminating resistor of 120 Ω between the RS485 and RS485 B connections on the circuit board of the last detector in the bus. The (switched) resistor is already built into the interface module IFM-485-ST. This properly terminates the data connection to both ends of the bus.
6. Connect the additional detectors to ground and 24 V supply.
7. Start com2tcp via the batch file.
The Windows console is displayed in a terminal window.
Note: This window must remain open as long as the connection is active! Otherwise it is not possible to access the IP module via the serial connection.
8. Start the ADPRO PRO E-Tool.

9. Select **Options, Com Port** and then select the COM port of the pair, which is **not** specified in the above batch file.
10. Select **Options, Search detector** (or [F3]) and start the search process.
The list now displays all connected detectors.
Note: If not all connected detectors are found it might be that not all detectors have a unique address. Refer to "Before mounting – detector address and basic configuration".
11. Double-click the entry of the detector in the Search list.
The detector signals are displayed in the scope panel.
For more details refer to the System Setup Manual (doc. no. 26571).

7.6 Reset IP module

Note: After a reset you must re-configure the IP module, see "Setup in DeviceInstaller".

To reset the IP module to factory settings proceed as follows:

1. To access the IP module board open the detector housing.
2. Connect (jumper) the two pins highlighted in the illustration below.

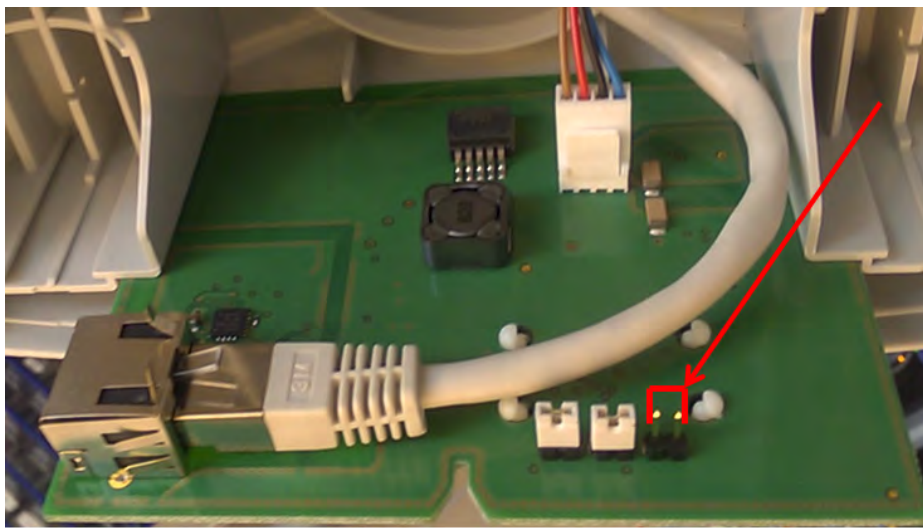

3. Energise the IP module board.
4. Wait 10 seconds for the board to be reset to factory settings.
5. Remove the jumper from the two pins.
6. Close the detector housing and tighten the screws.

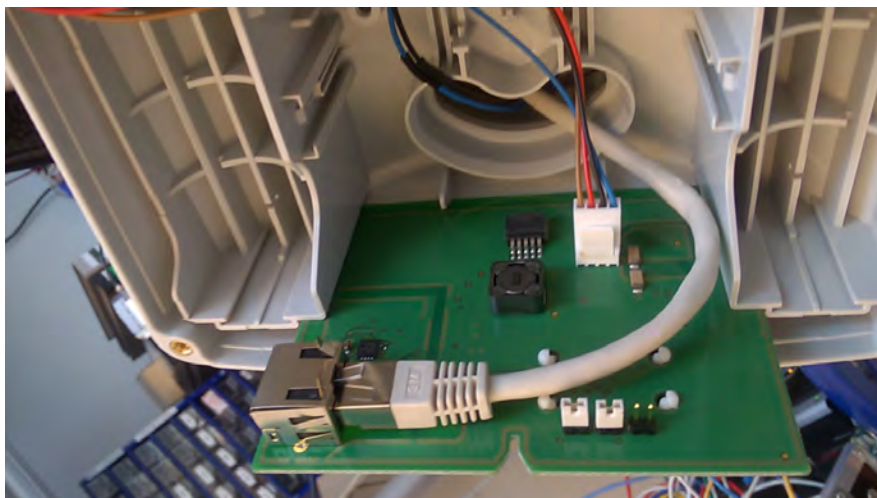

8 Detector alignment

Detectors can be aligned by two persons. If mobile device and PC have Internet connection then you can use a remote access tool (e.g. TeamViewer) to access the ADPRO PRO E-Tool while carrying out functional tests and walk test. This chapter describes the alignment of a detector by one person with the aid of the recommended accessories telescope, iCommission as well as wireless walk tester.

Notes:

- For background information on positioning and alignment of detectors refer to ADPRO PRO E PIR System Design and Planning Guide, document no. (27387).
- Do not align the detector in a way that it directly points towards a wire fence. Also, there should be no objects that are likely to be moved by the wind (such as branches, shrubs, fences) or waters in the detection range.
- Ensure that the three screws that attach the detector to the detector arm are not tightened but kept loose.
- Never align the detector by pressing down such that the field of view ends at the perimeter boundary (0 m. object height).
- To ensure detector efficiency, the object height must be configured to be 2 m at the perimeter boundary.
- The stipulated mounting height of 2.5 m to 4 m above ground should be maintained. 4 m is the minimum height at which the detector operates at its standard maximum range and is also optimally tamper-proof.
- Shadow nets or fence sheeting can be used to avoid detection of targets beyond the desired range. The width of this terminating material depends on the nominal width of the respective detector.

8.1 Installation of the telescope

The following telescope variants are available:

- Alignment Telescope for PRO E-series including adapter (CH18000101)
- Adapter for Alignment Telescope (CH11001201)
- Alignment Telescope for ADPRO PRO & Intrinsically Safe Series (AD851)



1. Install the adaptor supplied with the telescope as shown on the housing cover and slip on the telescope.
2. Attach the telescope to the adaptor with the help of the straining screws.

8.2 Alignment with the help of the telescope



1. Take a bearing on the perimeter area to be monitored using the rear and front sight on the detector cover, or optimally use the optional telescope, as shown.

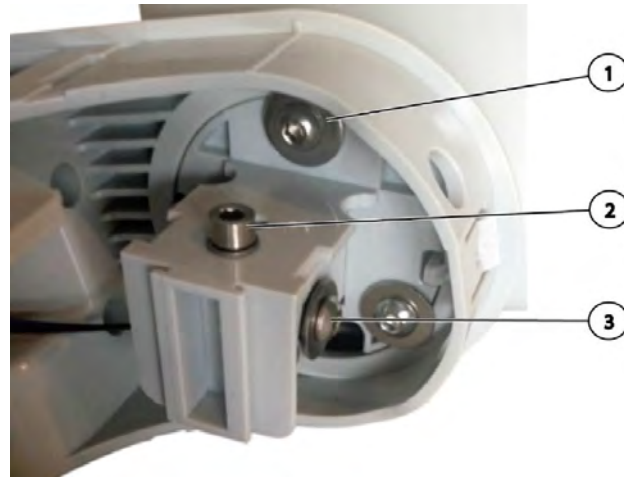

2. Loosen the three fastening screws (1) of the detector somewhat if required.
3. Loosen the locking screw (2)
4. Move the detector in the vertical direction over the spindle screw (3)

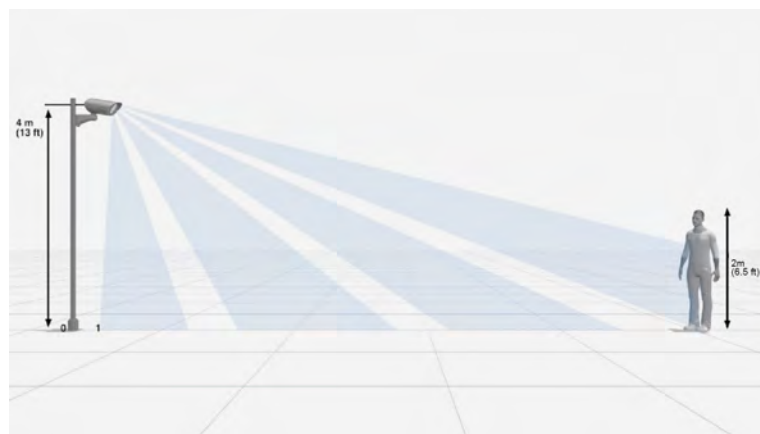

5. Sight a person or fixed point in the field of view of the detector at a height of 2 m. Use a 2-m visual warning sign or a three-legged tripod with a rod bearing 2 m marks.

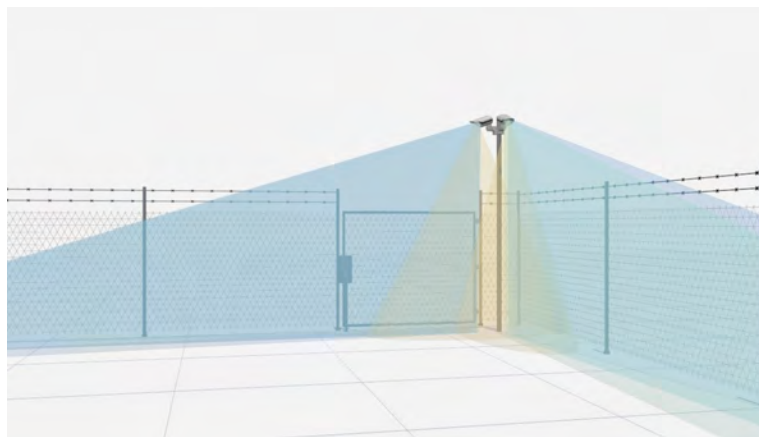

6. One side of a detector edge runs along a fence or the external horizontal perimeter boundary.
7. The other edge for a curtain detector or the inner edge for a volumetric detector moves into the interior of an area through the aperture angle.
8. The visual marker or the object should be approximately in the center of the monitored area, namely, the center of the nominal maximum width.
9. Correct horizontal adjustment (namely, along the fence) is what is important during this phase.
10. The vertical dip angle can be adjusted later either manually or more conveniently with iCommission. See section iCommission (one-person commissioning).
11. Use iCommission or CT PRO 2 to check whether the detector is detecting.

8.3 iCommission (one-person commissioning)



WARNING:

The device must not be used in potentially explosive areas, or areas where work with hazardous substances is being carried out.

iCommission is a tool which helps to vertically align a PRO E detector from a distance of up to 220 meters.

It consists of:

- The iCommission unit, which hooks onto the vertical alignment screw on the detector.
- The iCommission iOS app for compatible iOS devices (Apple iPhone, iPad, iPod touch).



Front view with user panel



Rear view with WiFi antenna, 4mm Allen/Hex key driver and clamps

8.3.1 Front view

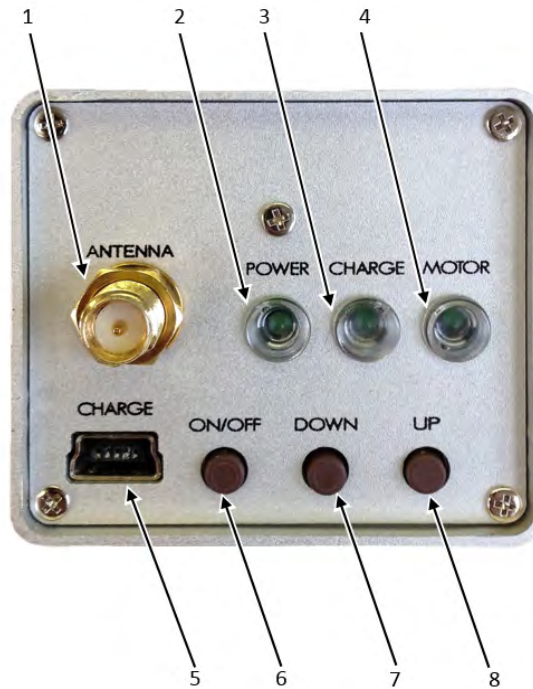

1	RP-SMA-connector Use to install included WiFi antenna
2	Power LED Lit when unit is switched on
3	Charge LED Lit while unit is being charged
4	Motor LED Lit while detector is moving up or down
5	Mini-USB port Charge iCommission with USB charger
6	ON/OFF button Press to switch iCommission on/off
7	DOWN button Press to lower detector
8	UP button Press to raise detector

8.3.2 iOS app

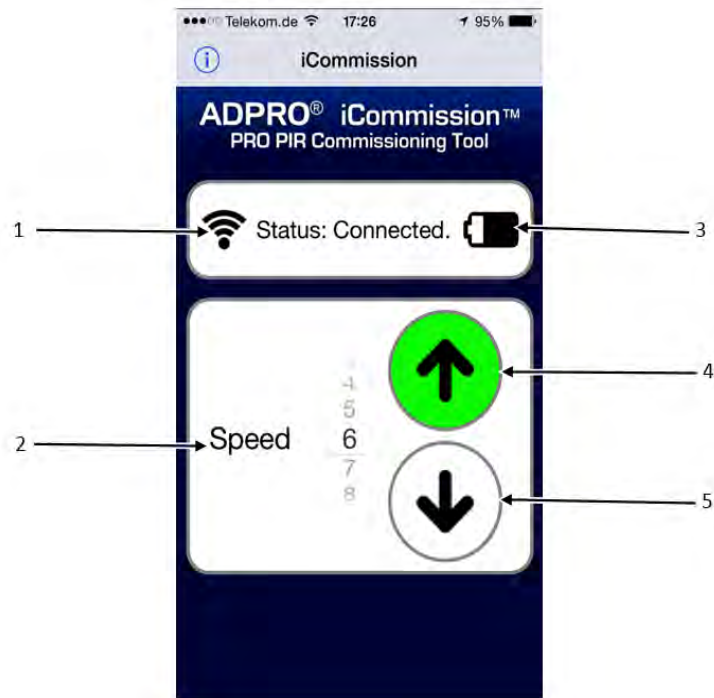

1	WiFi indication Shows connection status between iOS device and iCommission unit
2	Speed selection Roll to select speed of movement from slow (1) to fast (10)
3	Battery indicator Shows charge level of iCommission battery
4	UP button Tap for brief or hold for continuous raising of the detector
5	Down button Tap for brief or hold for continuous lowering of the detector

8.3.3 iCommission Installation and alignment

To install the tool and align the detector, follow these steps:

1. Search for “Xtralis” in the App Store, scroll to the iCommission app and tap “GET” to install it.

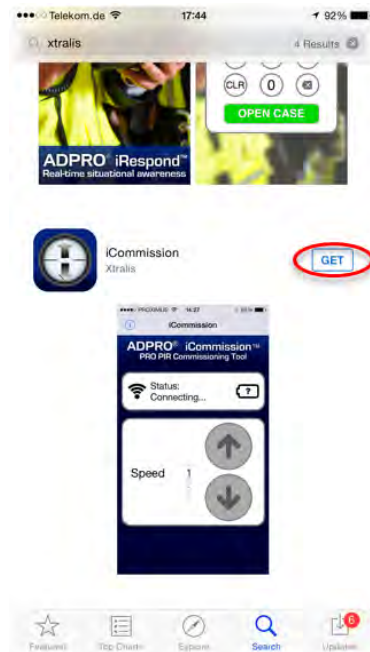

2. Make sure that the iCommission unit is fully charged, using an USB charger and a mini USB cable, place it on the vertical alignment screw of the PRO E detector as shown below:



3. Make sure that the 4mm hexagon driver connects inside the alignment screw and the outside clamps lock properly on the bracket.
4. Switch on the unit by pressing the left button until the LED switches on. After a few seconds, the iCommission creates its own WiFi hotspot with the following details:

SSID: iCommission-by XTRALIS

Password: 12345678

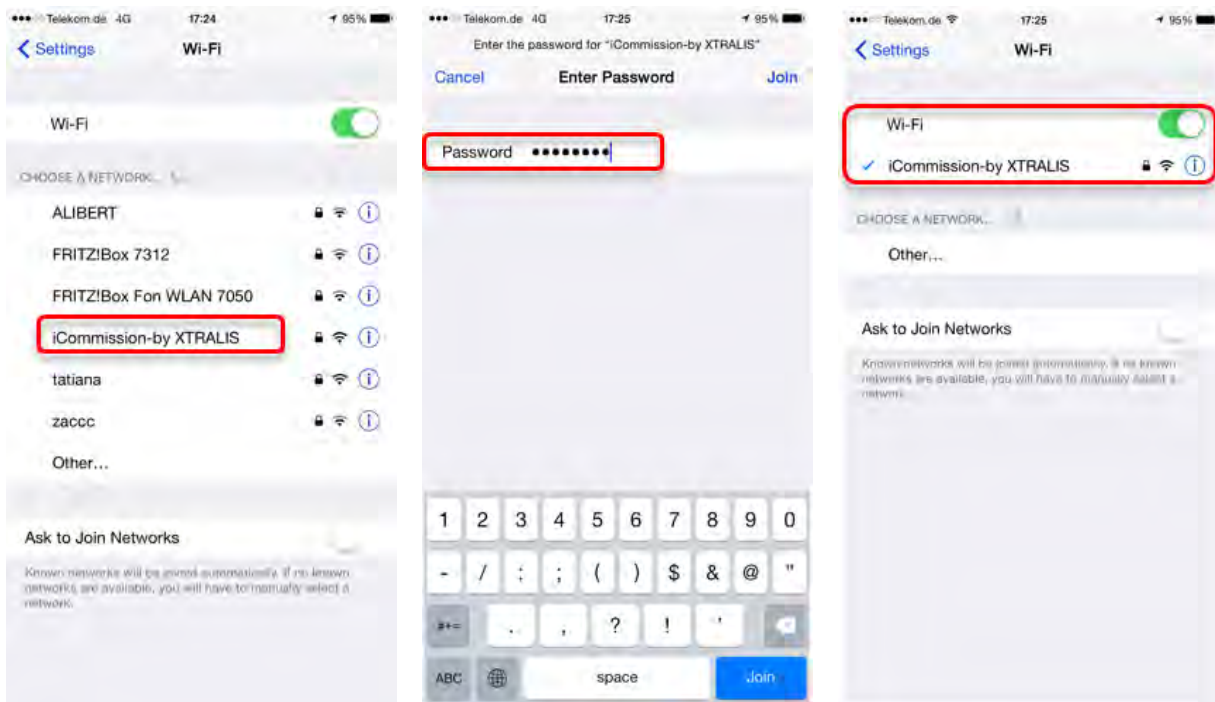

5. Use the up/down buttons on the front panel to roughly align the detector.



6. Perform walk test at $\frac{1}{4}$, $\frac{1}{2}$ and full nominal range.
7. Use CT PRO 2 (see section "CT PRO 2 – wireless walk tester"), iPIR app with FastTrace 2 or remote controlled PC running PRO SW to determine performance and fine tune sensitivity.
If performance is still unsatisfactory, start the iCommission app and remotely change the vertical alignment up or down until the required performance is reached.

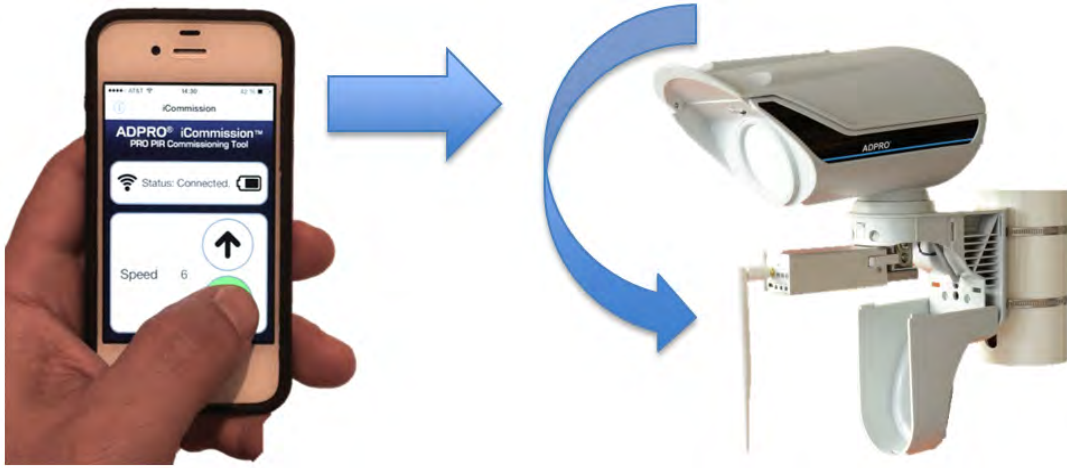

When the detector has full performance across the desired range, the vertical alignment is done and the iCommission unit can be removed. Continue with the commissioning process.

8.4 CT PRO 2 – wireless walk tester

8.4.1 General and Safety Information



WARNING:

The device must not be used in potentially explosive areas or areas where work with hazardous substances is being carried out.

Make sure you have the right detector/frequency for your area. You are responsible for determining whether you may use the detector in your country. See the transmitter specifications below (“Technical Data”) for information on frequency and power output. In general, transmitters marked EU or CE are suitable for use in Europe, and transmitters marked FCC are suitable for USA operation.

If the installation and usage instructions in these directions are not observed, the manufacturer’s liability for damages or violations is expressly excluded for:

- Not using the device as is intended
- Installation of non-original spare parts
- Unauthorised modification without written approval by the manufacturer
- Use of unauthorised equipment
- Ignoring important information on the Honeywell website

8.4.2 Intended use

CT PRO 2 is a wireless walk test unit which consists of a transmitter and a battery-operated hand-held receiver which continuously displays the PIR signal level and alarm status by LEDs and a buzzer. CT PRO 2 was specifically developed for the vertical alignment of Passive Infrared detectors of the ADPRO PRO and PRO E series in outdoor areas. The exact detection zone (width and length) can be configured precisely during installation or during the recommended walk test. The zone can extend up to 200m (650ft) and is thus suitable for all ADPRO PRO and PRO E detectors.

8.4.3 Device description

Using the CT PRO 2 wireless walk tester you can precisely align detectors over the entire nominal detection range. Optical-acoustical displays, as well as an LED bar displaying signal strength received at the detector make this product an absolute ‘must-have’ tool.





The CT PRO 2 consists of a transmitter which is connected via a connection cable to the RS-485 output of the detector and a mobile battery-operated receiver.

LEDs

- Power
 Power: A bright LED indicates that the device is switched on and the battery is okay. A weak or dimmed LED indicates insufficient voltage.
 On: receiver switched on, alarm buzzer off
 Flashing: receiver and alarm buzzer switched on
- Connectivity
 This LED indicates operable communication between transmitter and receiver.
 Flashing: receiver connected to transmitter
 Off: no transmitter within range
- Signal
 This LED bar graph displays the detection of a test person during the walk test, i.e. the current signal strength of the IR sensor in the detector.

Note: Existing CT PRO 2, which are used for the commissioning of the ADPRO PRO detector series, can still be used. However, the following item must be ordered: Interface adapter cable PRO E IFCRS-485 for PRO E-detector (article no. CH12001001).

Control Buttons

	Switch on/off receiver
	Switch on/off alarm buzzer

Technical Data

Range of CT PRO 2	Up to 200m (650ft)
Power	9V/PP3 block Lithium battery
Frequency	2.4GHz
Max radiated power	6.5 dBm EIRP (~10mW)

8.4.4 Walk tester commissioning

The transmitter is connected to the RJ12 socket inside the detector. Please note that the regular RS 485 communication (lines A&B) must be disconnected.

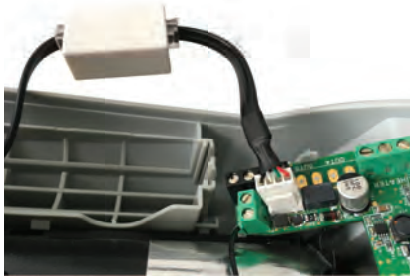

CT PRO 2 connection with ADPRO PRO E

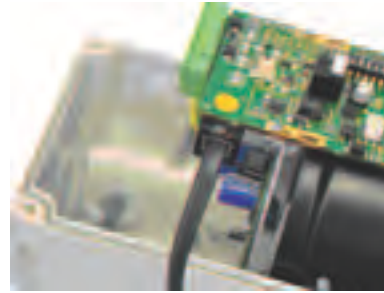

CT PRO 2 connection with ADPRO PRO PIR

Then the transmitter strapped horizontally on top or bottom of the housing using the Velcro tape supplied.



Proceed as follows:

1. Connect the transmitter as described above.
2. Switch on the receiver. After switching it off, wait at least 3 seconds before switching it on again.
3. Wait until the yellow LED starts flashing.
4. The red LED bar graph shows the current signal strength, and the buzzer indicates the actual alarm.

8.4.5 Perform walk test

1. Test the basic functioning using the walk tester at a spot near the center of the detection range.
2. Walk around in the detection range and check the receiver reading. Walk along the borders but also across the detection range so that both limits and the center of the detection range are taken into account.
3. To prevent false alarms, repeatedly leave the detection range. This way you can make sure that there is no detection outside the detection range.

If required correct the detector alignment, if appl. using the iCommission tool, see section "iCommission (one-person commissioning)". Also, if required, change the detector's sensitivity in the ADPRO PRO E-Tool, see ADPRO PRO E PIR System Setup Guide, document no. 26571.

8.4.6 Troubleshooting (walk tester)

Problem	Remedy
Connectivity LED does not flash	Check the connection of the transmitter and the distance to the receiver (150m max.).
When switching on the device all LEDs light up once and then go out	Replace the 9 volt battery (PP3).
Unit doesn't switch on right after switching off	Wait for 5 seconds before switching the receiver on again.

8.5 After alignment

Note: When restoring the operable state of the detector prevent inadvertent detector misalignment due to rotating or swivelling it.

After completion of the walk test restore the operable state of the detector as follows:

1. Remove the transmitter of the walk tester as well as the iCommission module from the detector.
2. Tighten the mounting screws of the detector holder at the wall or the screw clamps on the pole respectively.
3. Close the housing cover of the detector, insert the fastening screws and tighten them.
4. Tighten the hexagon socket head screws on the detector holder.



5. Close the holder bracketed so that the flap audibly snaps into place.
6. Adjust the tamper switch. Refer to section "Fine adjustment of tamper switch".
7. Test the overall installation for proper functioning.
If required repeat the alignment and further configure the detector using the ADPRO PRO E-Tool, see ADPRO PRO E PIR System Setup Guide, document no. 26571.

This page is intentionally left blank.

9 Technical data

Please note that fundamentally, there are 2 different versions:

- Standard version
- High performance – version (H version)

The H version is distinguished by the following enhanced features:

- The housing front pane is not made up of IR-transmissive sheeting, but a silicon-wafer pane which was developed specifically for this application and is distinguished by its high transmissivity to IR radiation.
- Camera-like look & feel
- Because of its precision optics, its nominal ranges are greater than those of the standard versions
- H-versions include an in-built heating mechanism
- Because of this heating, they can also be used in harsh climatic conditions. The detectors can be used despite temperature fluctuations because any air condensation that occurs, that could in turn damp signals due to the very small water droplet formation in the front pane or on the mirror, is counteracted.
- Additionally, there are two freely programmable zero potential relay outputs

The specifications below apply to all ADPRO PRO PIR detectors.

Technical Specifications	All ADPRO PRO E-detectors	
Spectral response	8-14 μm , double filter	
Detection speed	0.2 - 5.0 m/s	
Sensitivity or range (with ADPRO PRO-Tool-software)	20-140% (model specific)	
Filter (window)	Standard version:	HDPE filter, IR-transmissive
	High performance H versions:	Silicon wafer (silica glass)
Vandalism detection, housing	Misalignment and aperture monitoring (NC contact 30 V / 100 mA)	
Alarm display	Internal LED	
Alarm outputs	5 outputs per 75 mA max. at 60 V _{DC}	
Communication	RS-485, 9.6 kBit/sec	
Temperature compensation	Full compensation across the entire nominal operating temperature range	
Power supply	A PS1 Class (15W) power supply according to EN62368 should be used	
Current consumption	18 mA @ 12V _{DC} , 14 mA @ 24V _{DC}	
Power consumption, heating	0.5 W / ~41 mA @ 12 V _{DC} and -40°C (only H versions)	
Operating temperature, nominal	Standard versions:	-20°C to +60°C
	High performance H versions:	-40°C to +60°C
Cabling (terminal screws)	2 x 4-7 mm (0.16" - 0.27")	
Cable bushing	Cable exterior: \varnothing : 9 – 14 mm	(M16)
Dimensions (L x W x H) in mm	247 x 100 x 104	
Installation	<ul style="list-style-type: none"> • Pole installation • Wall installation 	
IP protection rating	IP66	

Technical Specifications	All ADPRO PRO E-detectors
Norms and guidelines	Designed to meet the following norms and guidelines: UK: BS8418_Form 172*) Basic Guide for Installers (CCTV with PIR trigger) *) subject to condition that all detectors are permanently monitored over an RS-485 data line via intrusion detection/access control/video monitoring systems, or via a risk management system through a 24x7 alarm receiving system (n) (ARS) in accordance with DIN EN 50518-1.
	ADPRO PRO E-PIR Tool detectors were third party tested and fully meet the following standards:
	2014/30/EU EMC Directive 2001/95/EC GPS Directive 2011/65/EU RoHS2 Directive
	EN 50130-4:2011 EN 61000-6-3:2007 + A1:2011 EN 62368-1:2014 EN 50581:2012
	HS Code (Commodity Code)
UN/SPSC code	46171632 (PIR detectors)
Country of origin	China
Development	Designed in Switzerland "Swiss Premium Quality"

10 Maintenance and cleaning

The following guidelines must compulsorily be followed in the maintenance of the detector, and in particular its cleaning:



CAUTION:

The housing of intrinsically safe XtralisADPRO PRO E-detectors is made of non-metallic material.

During installation, ensure that these are not mounted in dust-laden surroundings, in particular if it is a high speed version!

To prevent electrostatic charge, clean only with a damp cotton cloth!

Failure to comply will result in cancellation of the license!

10.1 Firmware update (ADPRO flashloader)

Notes: For a firmware update on a detector you need the ADPRO Flashloader software. Download the latest firmware from the Xtralis partner portal (www.xtralissecurity.com; doc.-no. 29461). The download file contains the actual firmware but also the installation file of the ADPRO Flashloader software.

Install ADPRO Flashloader

Proceed as follows:

1. Unpack the download file and install the ADPRO Flashloader software on your computer.
2. Rename the file Setup_AdproFlashloader_2.0.txt to Setup_AdproFlashloader_2.0.exe.
3. Double-click on Setup_AdproFlashloader_2.0.exe and follow the instructions on screen.

Install firmware on detector

Note: Updating the firmware will cause all detector settings including the output settings to be reset factory settings. We recommend that you save the settings to separate files as described in the instructions below. For details on the Setting and Output settings dialogues refer to ADPRO PRO E PIR System Setup Guide, document no. 26571.

Proceed as follows to update the firmware:

1. Open the ADPRO PRO E-Tool and connect to the detector to be updated.
2. To save the detector settings select **Settings, Settings** and then **Setting, Save** (or press [Ctrl]+[S]). Enter a meaningful file name and confirm with **Yes**, and close the Setting dialogue.
The configuration file (.CFG) is stored in the sub-folder CFG of the ADPRO PRO E-Tool program folder.
3. To save the detector's output settings select **Settings, Output settings** and then **Settings, Save** (or press [Ctrl]+[S]). Enter a meaningful file name and confirm with **Yes**, and close the Output settings dialogue.
The configuration file (.CFO) is stored directly in the ADPRO PRO E-Tool program folder.
4. Close the ADPRO PRO E-Tool or any other programs which might use the COM port connected to the detector.
This is to make sure that the COM port is available for the connection to the IFM-485 and to the detector "Establish connection from PC via IFM-485-ST".
5. Start ADPRO Flashloader.

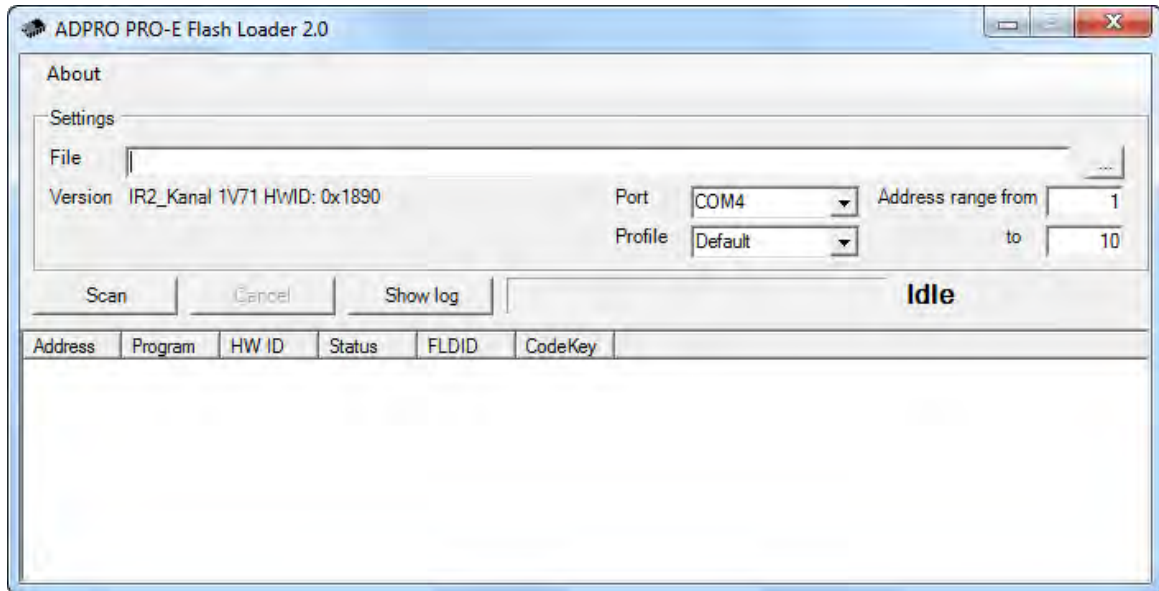

6. In the **Port** list select the COM connected to the IFM-485 and thus to the detector.
7. Set **Profile** to Default.
8. In the fields **Address range from / to** enter the address to be scanned for detectors. A small range accelerates the look-up process. If no detector is found, enhance the address range (max. 254).
9. Under **File** load the firmware file which is suitable for the respective detector type. Click on and select the file using the file dialogue.

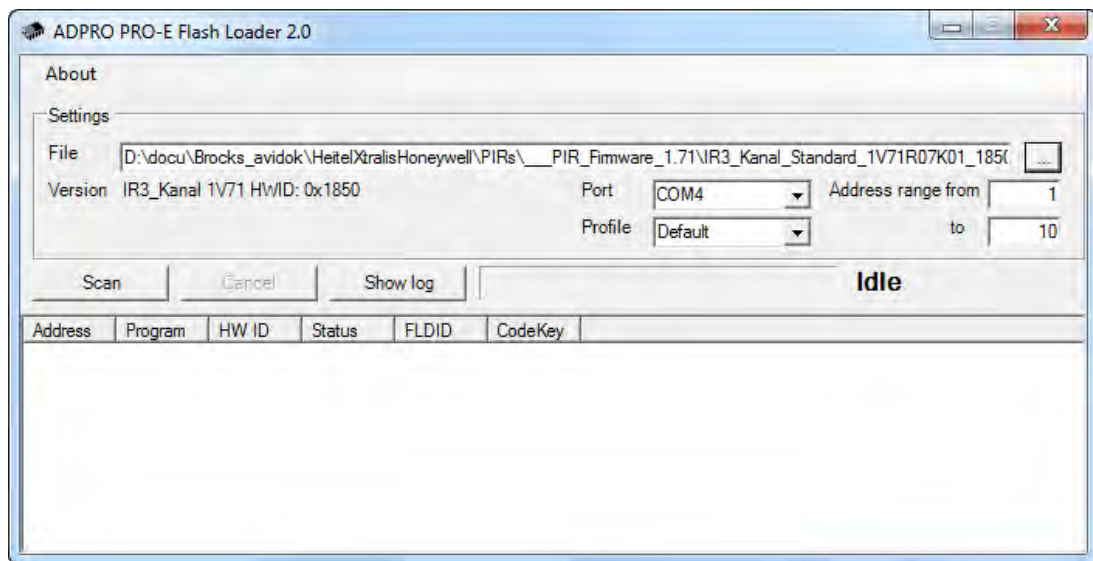

10. To find the detector click on **Scan**.
11. In the result list click on the item of the desired detector to select it (ticked off in column Program, selecting multiple items is possible).

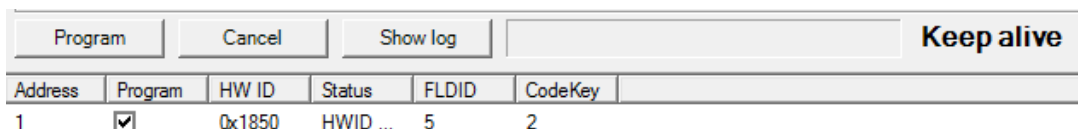

12. Click on **Program**. The update progress is displayed.

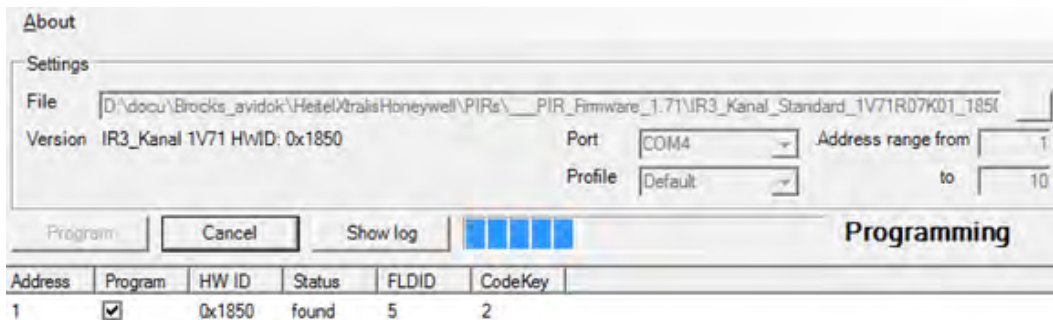

13. If you wish to check the log after completion of the process, click on **Show log**. Use the **Save** button to save the log to a text file.

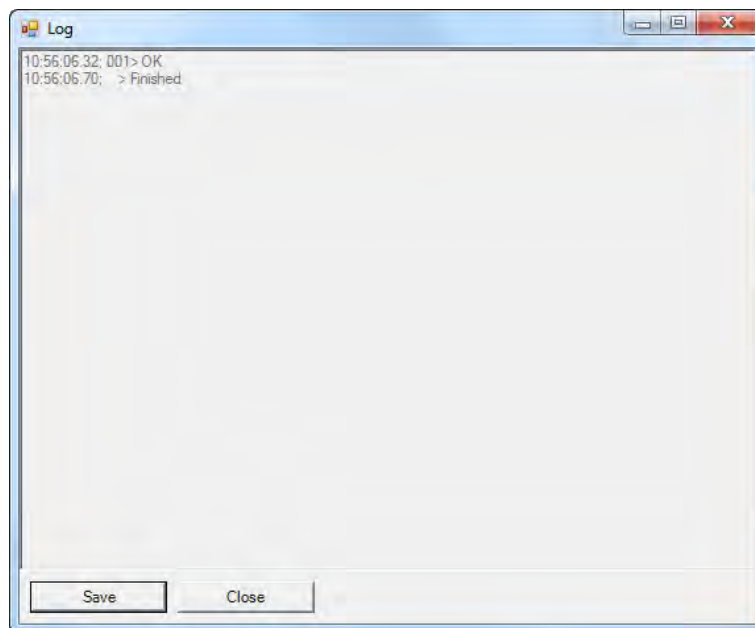

14. Close the ADPRO Flashloader application.
This is required because otherwise the COM port is not available for the ADPRO PRO E-Tool.
15. Open the ADPRO PRO E-Tool and connect to the detector see section "First detector connection".
16. To load the previously saved detector settings select **Settings, Settings** and then **Setting, Open** (or press [Ctrl]+[O]). Double-click on the file in the list or select it and click **Open**.
17. Select **Setting, Write settings to detector** (or [Ctrl]+[D]). Close the Settings dialogue.
18. To load the previously saved output settings of the detector select **Settings, Output settings** and then **Settings, Open** (or press [Ctrl]+[O]). Double-click on the file in the list or select it and click **Open**.
19. Select **Settings, Write settings to detector** (or [Ctrl]+[U]). Close the Output settings dialogue.
20. Check the settings and functioning of the detector.

Now you can use the detector with the new firmware. In case of errors reported during firmware update, please refer to section "Troubleshooting".

10.2 Replace filter

Note: Take great care particularly when handling silicon wafers because they are brittle. Make sure the new filter is installed in a clean and dry state.

The wafer is held by a locking ring (bayonet catch). For replacement you need two precision screwdrivers or metal pins as tools which fit into the small openings at the circumference of the locking ring. Proceed as follows when replacing the wafer:

1. Insert the two tools in two opposite holes in the locking ring.
2. Turn the locking ring anti-clockwise to disengage it. It might be that the ring slightly sticks to the sealing ring below.

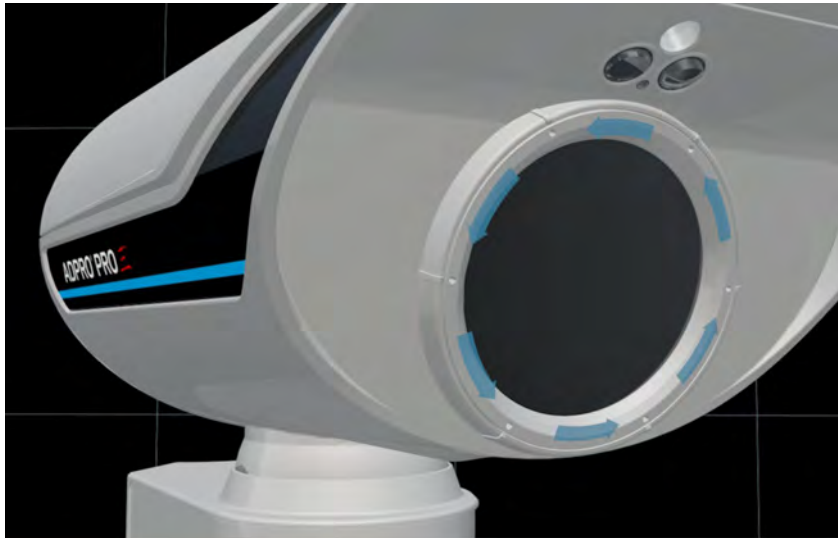

3. Carefully lever the ring out.
4. Remove the filter.



5. Clean the seat.
6. Insert the new wafer.
7. Insert the locking ring.
8. Lock the ring by turning it clockwise using the two tools. The holes must be aligned with the marks at the circumference.

Note: Do not apply isolated pressure on silicon wafers because they easily break.

10.3 Retrofit creep zone blinder

Note: The creep zone blinder is not available as accessory part. In case of loss or damage, please contact the Xtralis team directly.

For various models creep zone blinders have been temporarily supplied as separate accessory. Since January 2018 the blinders are factory-installed. For mounting the blinders you need weather-resistant and solvent-based adhesive (e.g. PVC-U von Tangit).

Proceed as follows in retrofit:

1. Ensure a clean, dry bonding surface which is free from grease.
2. Apply adhesive according to the manufacturer's instructions.

Notes: Avoid excess adhesive which could cover the creep zone detector. Observe the manufacturer's temperature specifications for usage of the adhesive.
3. Press the blinder on the bonding surfaces so that it is a tight fit around the creep zone detector. Maintain the contact pressure according to the adhesive manufacturer's instructions.

4. Check the creek zone detector for cleanliness.
5. Test the functioning of the detector.

This page is intentionally left blank.

11 Troubleshooting

The following sections describe common error patterns and remedial action:

- No detectors found in ADPRO PRO E-Tool.
- Specific detector not found in ADPRO PRO E-Tool.
- Firmware update failed (Troubleshooting firmware update (ADPRO Flashloader))
- False alarms.

11.1 No detectors found in ADPRO PRO E-Tool

If no detectors are found the following error message is displayed in the ADPRO PRO E-Tool after completion of the search process:

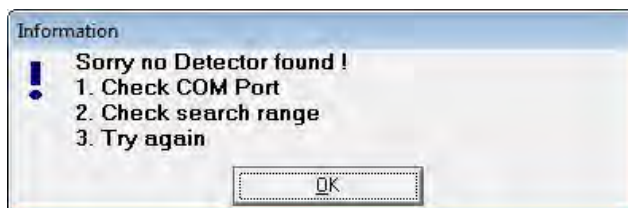

Check the aspects described below.

Start sequence

Make sure that at first all detectors are energised and that the detector start-up is completed before you start the ADPRO PRO E-Tool and the search process (**Options, Search Detector** or [F3]). The detector(s) must be up and running. Otherwise the search process cannot find them.

COM port

Make sure that you have selected the correct COM port in the ADPRO PRO E-Tool (**Options, Com Port**). The connection is indicated during the search process by the flashing TX LED on the IFM-485-ST. When a detector is found then the also RX LED flashes on the IFM-485-ST.

Search range

In the ADPRO PRO E-Tool select **Options, Search Detector** or press [F3]. The Search Detector dialogue is displayed:

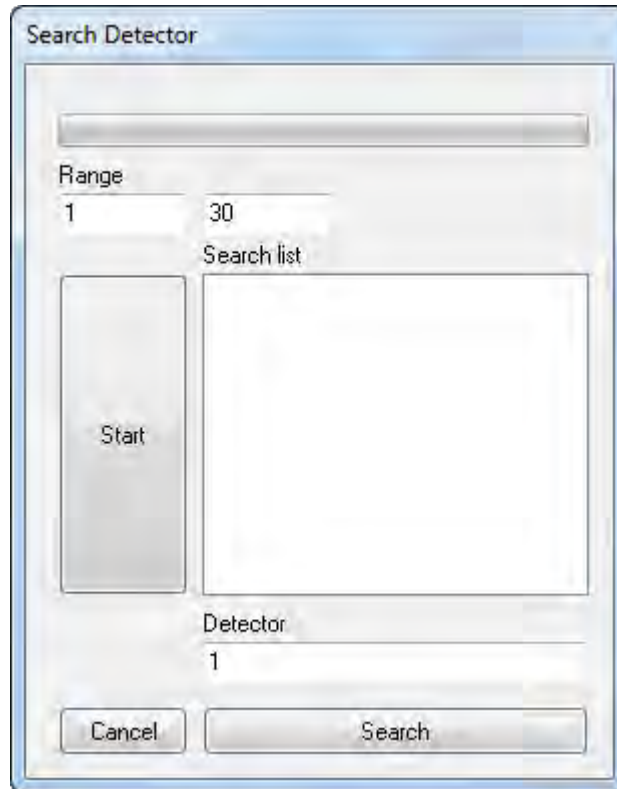

The two **Range** fields serve to define the address range to be scanned in the search process. In the example above the address range covers the addresses 1-30, which accelerates the search process. However, detectors with an address 31 or higher will not be found. If required, extend the search range to the maximum range (1 to 254). However, this will slow down the search process.

Timeout

It might happen that the ADPRO PRO E-Tool does not find detectors because the search process is cancelled due to a timeout. You can increase the threshold value for the timeout.

Note: When changing the configuration file take great care that you do not accidentally change or delete values. If this happens you might have to re-install the software in order to reset the software to factory settings.

Proceed as follows to increase the threshold value for the timeout:

1. Close the ADPRO PRO E-Tool.
2. Locate the file ADPRO.CFG in the program directory of the ADPRO PRO E-Tool.
3. Open the file using a text editor.
4. Increase the ComTimeout value to, e.g., 200. Higher values are possible but this will slow down the search process.
5. Save the changes and close the ADPRO.CFG file.
6. Open the ADPRO PRO E-Tool and repeat the search process.

11.2 Specific detector not found in ADPRO PRO E-Tool

Duplicate detector addresses

If a specific detector is not found this might be due to a detector address which was assigned more than once, refer to "Configure detectors". If multiple detectors have the same address and if they are connected to the same bus (IFM-485-ST), the search process in the ADPRO PRO E-Tool will find none of them. This might happen, e.g., if on one detector the factory setting (address = 1) was not changed as recommended and if then another detector is connected to the installation, which then also has the factory setting (address = 1).

If required, connect the detectors of your installation one by one to make sure that each address is only assigned once.

INI file not found

For the individual detector types the corresponding INI files are located in the INI directory of the ADPRO PRO E-Tool program directory. If the INI cannot be found the following error message is displayed:

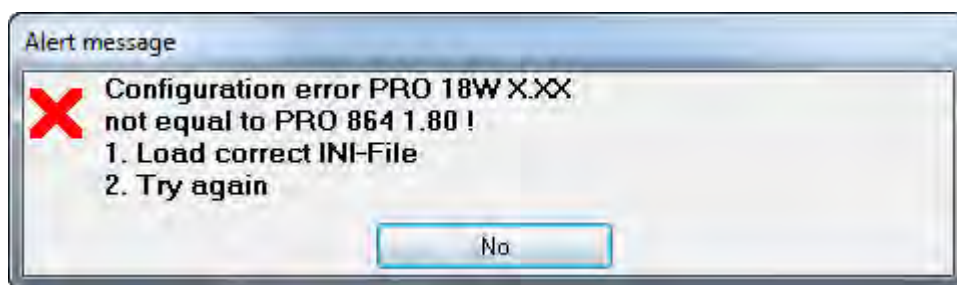

When connecting to a detector the ADPRO PRO E-Tool automatically selects the correct INI file for the respective detector type. However, if the above error message is still displayed, then your software might not be compatible with the detector. In that case, please contact our technical support for software update.

Before selecting a detector you can try manually to load a suitable INI file for your detector.

Note: The **Open Detector INI** function is a legacy function of the software which is not to be used in normal operation. Using the function forces the software to use the selected INI file. If the selected type does not correspond to the connected detector then an error message is displayed.

To manually load the INI proceed as follows:

1. In the ADPRO PRO E-Tool select **File, Open Detector INI** (or press [F2]).
2. In the dialogue select the respective detector type and click **Open**.

11.3 Polarity mismatch

Confusing poles in installation results in malfunction. Ensure correct connection (polarity) of

- Voltage supply
- RS-485 connection

Refer to "Overview of the circuit board".

11.4 Troubleshooting in firmware update (ADPRO flashloader)

Detector not found

If the ADPRO Flashloader does not find detectors, this might be due to the following reasons:

- Detector not installed correctly or communication port not configured correctly, refer to "No detectors found in ADPRO PRO E-Tool".
- Wrong port selected. Under Port select the COM port used for the connection to IFM-485 and to the detector, refer to No detectors found in ADPRO PRO E-Tool
- **Address range from / to** too small.
If no detector is found, increase the address range (1 to max. 254).



Error on update

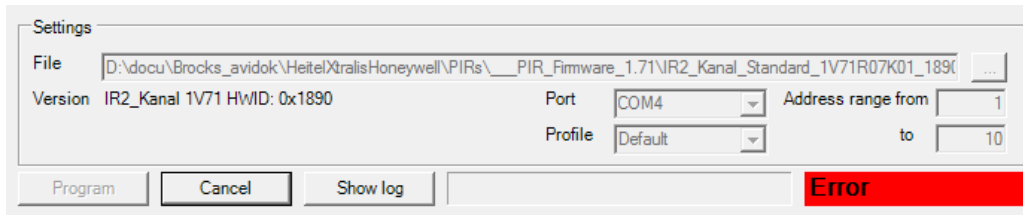

If the firmware update fails this might be due to the following reasons:

- No suitable detector found for the specified file (field **File**) or
- Update attempt with incorrect file

Select a firmware file which is suitable for the respective detector and try again.

11.5 False alarms

Possible cause	Remedy
Animals in the detection range	Check whether there are any animals. If required, fence in the detection range.
Vegetation moved by wind or animals	Monitor the detection range to check whether moving vegetation (such as branches and leaves) triggers alarms. Remove or cut the interfering vegetation.
Detector's alarm triggering sensitivity too high	If required adjust the sensitivity. Refer to ADPRO PRO E PIR System Setup Guide, document no. 26571.
Heat sources	Check to see if there heat sources within the detection range of the device (e.g. kitchen exhaust or waste heat from an air-conditioning system). Adjust the alignment of the device if necessary, or shield it from heat sources.

12 Dismantling and disposal

At the end of its useful life, the device must be dismantled and disposed of in an eco-friendly manner.

12.1 Work safety

Personnel

Work on the electrical system must be performed only by qualified electricians.

12.2 Measures before dismantling

Perform the following steps before you begin dismantling:

1. Switch off the power supply.
2. Protect the main switch with a padlock, so that it cannot be switched on.

12.3 Disposal

Damage to environment



CAUTION:

Risk to environment through improper use!

Improper use of substances that are hazardous to the environment, and in particular their improper disposal, can cause substantial environmental damage.

Hence:

- Always follow the instructions in this guide
- Initiate appropriate measures immediately if environmentally hazardous substances are released into the surroundings. Inform the responsible local authority of the damage in case of doubt.

Dismantled components must be recycled as follows:

- as scrap metal
- as plastic parts for recycling
- other components to be disposed off by sorting by material

You can obtain information about eco-friendly disposal at the competent local authority or at specialized waste disposal companies.

This page is intentionally left blank.

13 Declaration of Conformity

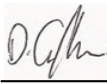
Declaration of Conformity		Honeywell
Product Type	: PIR Motion Sensor	
Product Model	: PRO E series (see below text fields)	
Manufacturer	: Xtralis AG Burgerriet-Strasse 30 CH - 8730 Uznach Switzerland	
Directives	: 2014/30/EU EMC Directive 2001/95/EC GPS Directive 2011/65/EU RoHS2 Directive	
Standards	: EN 50130-4:2011 EN 61000-6-3:2007 + A1:2011 EN 62368-1:2014 EN 50581:2012	
<p>Brand = ADPRO by Xtralis</p> <p>Product models: PRO E-18, PRO E-18H, PRO E-18W, PRO E-18WH, PRO E-30, PRO E-40, PRO E-45, PRO E-45H, PRO E-100, PRO E-100H PRO E-400H</p>		
<p>The Product described above is in conformity with the relevant European Union harmonisation legislation.</p>		
Signed	: 	
Full Name	: Darren Coffin	Title : Product Steward
On behalf of	: Xtralis	
Date of Issue	: 01 March 2018	Place : Newhouse, UK
<p><u>This declaration is issued under the sole responsibility of the manufacturer.</u></p>		

This page is intentionally left blank.

www.xtralis.com

UK and Europe +44 1442 242 330

Middle East +962 6 588 5622

The Americas +1 800 229 4434

Asia +86 21 5240 0077

Australia and New Zealand +61 3 9936 7000

A Disclaimer about this document, statements about Intellectual Property, Copyrights, and Liability, as well as a General Warning are available in an earlier section of this document.

Document No: 27386_07

ADPRO[®]
by  **xtralis**[®]