

Model BFV-300 Butterfly Valve Wafer Style

General Description

The TYCO Model BFV-300 Wafer Style Butterfly Valves (Ref. Figure 1) are indicating type valves designed for use in fire protection systems where a visual indication is required as to whether the valve is open or closed. They are used, for example, as system, sectional, and pump water control valves, and are suitable for installation between ANSI Class 125/150 flanges as well as PN10/16 flanges without the need for flange gaskets.

For applications requiring supervision of the open position of the valve, the Gear Operators for the Model BFV-300 Butterfly Valves are provided with two sets of factory installed internal switches each having SPDT contacts. The supervisory switches transfer their electrical contacts when there is movement from the valve's normal open position during the first two revolutions of the handwheel.

NOTICE

The TYCO Model BFV-300 Wafer Style Butterfly Valves described herein must be installed and maintained in compliance with this document, as well as with the applicable standards of the National Fire Protection Association, in addition to the standards of any other authorities having jurisdiction. Failure to do so may impair the performance of these devices.

The owner is responsible for maintaining their fire protection system and devices in proper operating condition. Contact the installing contractor or product manufacturer with any questions.

Technical Data

Sizes: ANSI Inches (DN)
2-1/2 (DN65), 3 (DN80), 4 (DN100),
5 (DN125), 6 (DN150), 8 (DN200),
10 (DN250)

Approvals
UL Listed
FM Approved
CE Certified

All laboratory listings and approvals are for indoor and outdoor use.

Maximum Working Pressure
300 psi (20,7 bar)

Maximum Working Temperature
According to UL 1091: 212° F (100° C)

Materials of Construction

Body
Ductile iron conforming to ASTM A536

Body Coating
Nylon: Rilsan Pine Powders (PA11) Black

Disc
Ductile iron conforming to ASTM A395

Disc Seal
Grade EPDM "E" encapsulated rubber conforming to ASTM D2000

Upper & Lower Stem
Type 416 Stainless Steel conforming to ASTM 582

Actuator
2-1/2 to 6 Inch – IP 65, bronze traveling nut gearbox with internal dual switch in ductile iron housing

8 to 10 Inch – IP 65, segmented gearbox with internal dual switch in ductile iron housing

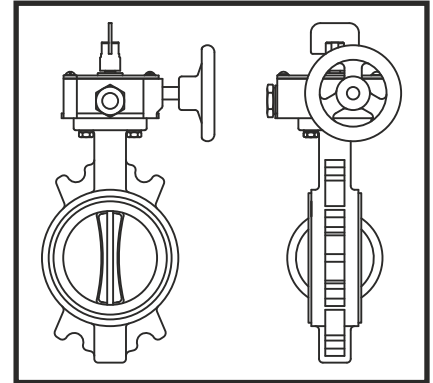

100% Silicone Free
BFV-300 Butterfly Valves are produced and assembled not using silicone lubricants in any form (such as: grease or aerosol spray) and are suitable for paint or oxygen applications.

Control Valve Seat Leakage Class IEC 60534-4
CLASS VI (Type C) Control Valve Seat Leakage according to ANSI/FCI 70-2-2006 (ASME B16.104)

Nominal Valve Sizes Inches (DN)	Nominal Installation Dimensions Inches (mm)								Weight Lbs. (kg)
	A	B	C	D	E	F	G	H	
2-1/2 (65)	1.81 (46)	11.67 (296,5)	3.35 (85)	5.45 (138,5)	4.92 (125)	4.28 (108,6)	1.99 (50,5)	1.65 (41,9)	13.4 (6,1)
3 (80)	1.81 (46)	12.27 (311,7)	3.58 (91)	5.81 (147,7)	4.92 (125)	4.28 (108,6)	1.99 (50,5)	2.34 (59,5)	14.1 (6,4)
— (80)	1.81 (46)	12.27 (311,7)	3.58 (91)	5.81 (147,7)	4.92 (125)	4.28 (108,6)	1.99 (50,5)	2.34 (59,5)	14.1 (6,4)
4 (100)	2.16 (55)	13.92 (353,5)	4.29 (109)	6.75 (171,5)	4.92 (125)	4.28 (108,6)	1.99 (50,5)	3.25 (82,6)	15 (6,8)
5 (125)	2.4 (61)	16 (406,6)	5.16 (131)	7.93 (201,5)	5.91 (150)	5.79 (147)	2.32 (58,9)	4 (101,6)	26.2 (11,9)
6 (150)	2.4 (61)	17.07 (433,6)	5.71 (145)	8.44 (214,5)	5.91 (150)	5.79 (147)	2.32 (58,9)	5.22 (132,6)	24.5 (11,1)
8 (200)	2.48 (63)	19.63 (498,5)	6.69 (170)	9.29 (236)	8.86 (225)	8.19 (208)	2.76 (70)	7.3 (185,4)	44.1 (20)
— (200)	2.48 (63)	19.63 (498,5)	6.69 (170)	9.29 (236)	8.86 (225)	8.19 (208)	2.76 (70)	7.3 (185,4)	44.1 (20)
10 (250)	3.03 (77)	23.01 (584,5)	8.27 (210)	11.1 (282)	11.14 (283)	8.19 (208)	2.91 (74)	9.05 (230)	63.9 (29)

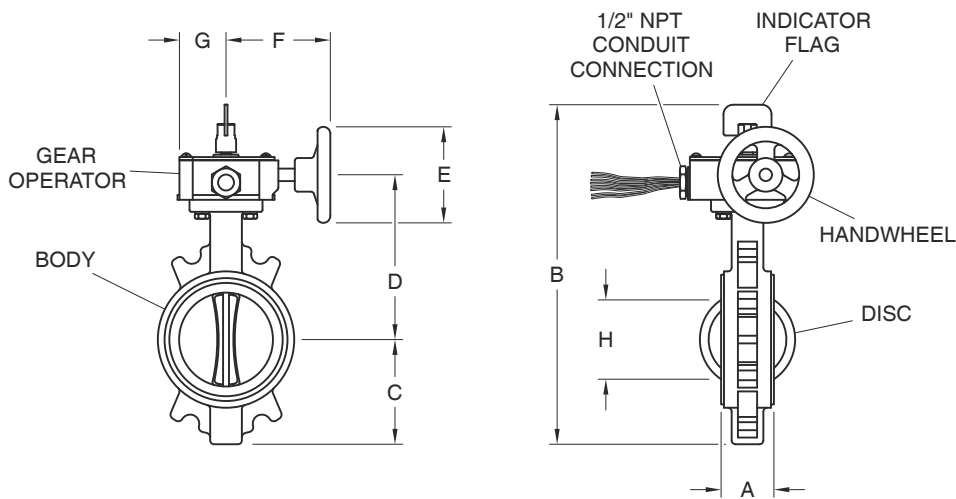

FIGURE 1
MODEL BFV-300 WAFER STYLE BUTTERFLY VALVE
NOMINAL DIMENSIONS

Detail	Part	Material	Qty.	Detail	Part	Material	Qty.	Detail	Part	Material	Qty.
01	Body	ASTM A-536	1	14	Stem Housing	Fe	1	28	Spring Pin Ø4x0.8tx25	ASTM A-228	1
02	Upper Stem	AISI 410	1	15	Spring Pin	ASTM A-228	1	29	Handle	ASTM A-536	1
03	Lower Stem	AISI 410	1	16	Indicator	ASTM A-619	1	30	Bolt (Round)	ASTM A-167	3
04	Disc	EPDM	1	17	O-Ring	NBR	1	31	Plate Washer	ASTM A-167	4
05	O-Ring (P12)	EPDM	4	18	Cover Gasket	Paper	1	32	Switch Assembly	—	1
06	Oiless B/R (MB1410)	—	4	19	Spring Pin Ø5 x 1T x 25	ASTM A-228	1	33	T/R Bolt	ASTM A-307	2
07	End Cap 2-1/2"-4"	EPDM	1	20	O-Ring (P10)	EPDM	1	34	Tapping Screw ST3.5 x 7.5	S10C	1
08	Gear Box	ASTM A-536	1	21	Worm Shaft	AISI 410	1	35	Tooth Washer 4#	S10C	1
09	2-1/2 to 6 Inch Traveling Nut	Bronze	1	22	Bushing (1)	FD-0205-45	1	36	Lever	ASTM A-619	1
09	8 and 10 Inch Segment Gear	C3604BD	1	23	Collor	FD-0205-45	1	37	Connector	—	1
10	Bushing (2)	FD-0205-45	1	24	Spring Washer	ASTM A-167	4	38	Sticker	—	1
11	Cover	ASTM A-619	1	25	Hex. Bolt M8 x 20L	ASTM A-167	2	39	Sticker	—	1
12	Bushing	Fe	1	26	Hex. Bolt M8 x 25L	ASTM A-167	2	40	Gasket	EPDM	2
13	Headless Wrench Bolt M5 x 7L	ASTM A-307	1	27	Gasket	Paper	1	41	Spring Pin Ø3x0.6T x 25	ASTM A-228	

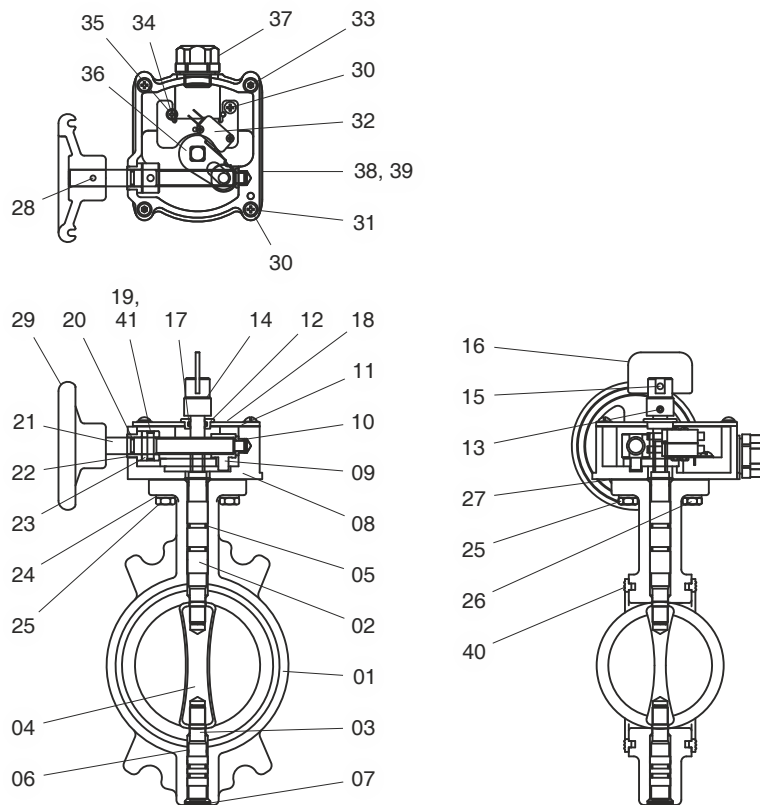
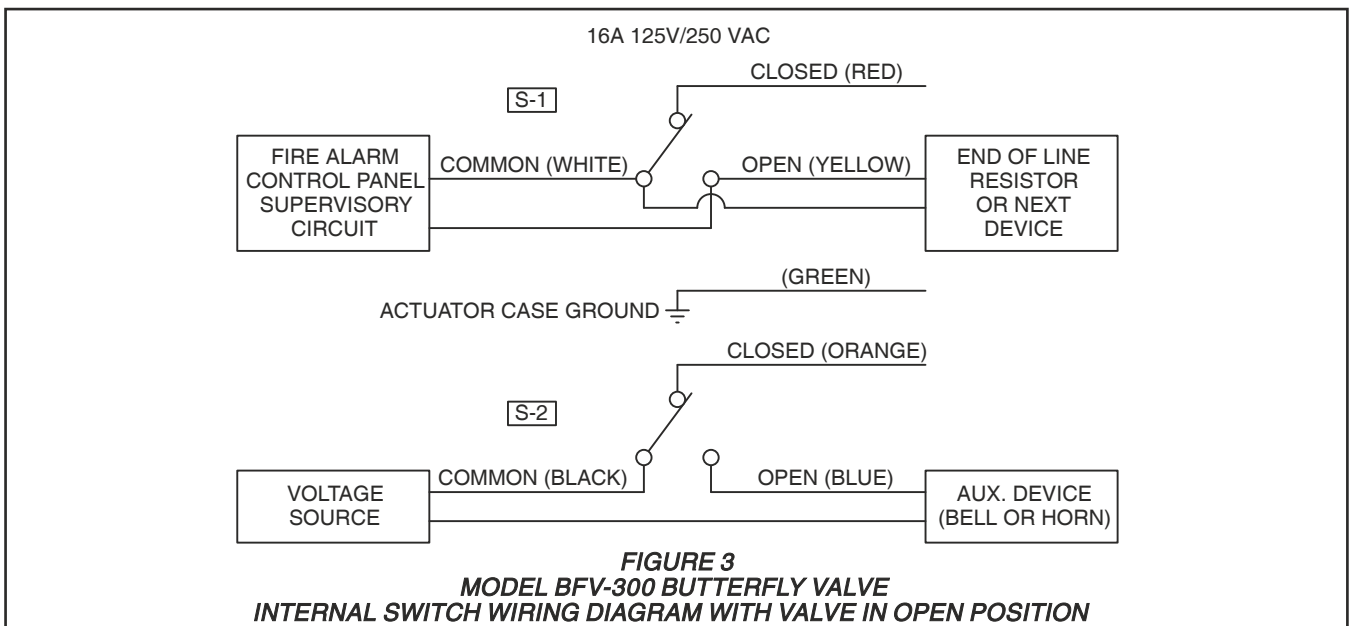
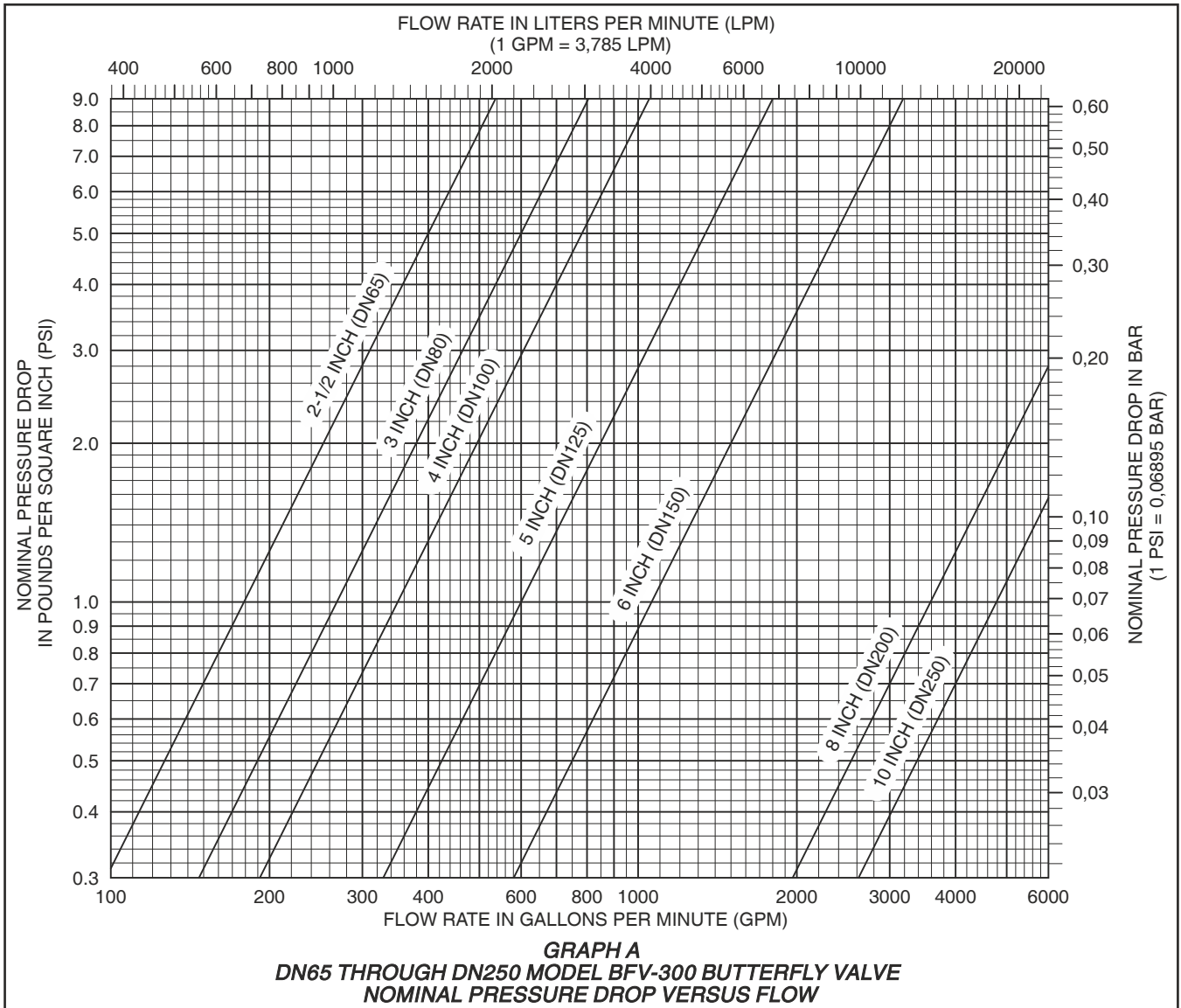

FIGURE 2
MODEL BFV-300 WAFER STYLE BUTTERFLY VALVE
ASSEMBLY DRAWING



Valve Size Inch (DN)	psi (bar)	Flange Face	Part Number With Internal Switch	Part Number Without Internal Switch	CE	UL	C-UL	FM	VdS	CCCf	APSAD	PAVUS	VNIPPO
2-1/2 (65)	300 (20,7)	ANSI 16.5, PN16	59300W025WS	59300W025NS	•	•		•					
3 (80)	300 (20,7)	ANSI 16.5	59300W030WS	59300W030NS	•	•		•					
— (80)	300 (20,7)	BS PN16	59300W036WS	59300W036NS	•	•		•					
4 100	300 (20,7)	ANSI 16.5, BS PN16, AS 2129 Table E	59300W040WS	59300W040NS	•	•		•					
5 (125)	300 (20,7)	ANSI 16.5, BS PN16	59300W050WS	59300W050NS	•			•					
6 (150)	300 (20,7)	ANSI 16.5, BS PN16, AS 2129 Table E	59300W060WS	59300W060NS	•	•		•					
8 (200)	300 (20,7)	ANSI 16.5	59300W080WS	59300W080NS	•	•		•					
— (200)	300 (20,7)	BS PN16	59300W086WS	59300W086NS	•	•		•					
10 (250)	175 (12)	ANSI 16.5, BS PN16	59300W100WS	59300W100NS	•	•		•					

TABLE A
MODEL BFV-300 WAFER STYLE BUTTERFLY VALVE
WITH OR WITHOUT INTERNAL SUPERVISORY SWITCHES
PART NUMBER SELECTION AND AGENCY LISTINGS/APPROVALS

Valve Size Inch (DN)	Part Number		
	Bernstein i88-IP65 Regular Switch	Bernstein i88-IP65 LED Switch-24V	Bernstein GC-SU1Z Ex IP-66/67 ATEX (II 2 Ex d IIC T6) Switch
2-1/2 to 4 (65 to 100)	59300SPBRACKSW10	59300SPBRACKSW10LED	59300SPBRACKSW10ATEX
5 to 6 (125 to 150)	59300SPBRACKSW20	59300SPBRACKSW20LED	59300SPBRACKSW20ATEX
8 to 10 (200 and 250)	59300SPBRACKSW30	59300SPBRACKSW30LED	59300SPBRACKSW30ATEX

TABLE B
MODEL BFV-300 WAFER STYLE BUTTERFLY VALVE
MOUNTING BRACKET ASSEMBLY WITH BERNSTEIN EXTERNAL SWITCH
PART NUMBER SELECTION

Valve Size Inch (DN)	Part Number
2-1/2 to 4 (65 to 100)	59300SPHWHEEL10
5 to 6 (125 to 150)	59300SPHWHEEL20
8 to 10 (200 and 250)	59300SPHWHEEL30

TABLE C
BFV-300 WAFER STYLE BUTTERFLY VALVE HANDWHEEL WITH PIN
PART NUMBER SELECTION



Nominal Flange Size ANSI Inches (DN)	Recommended Minimum Torque Ft.-Lbs (Nm)
2 - 4 (50 - 100)	20 - 30 (27,1 - 40,7)
5 - 8 (125 - 200)	33 - 50 (44,7 - 67,8)
10 (250)	53 - 75 (71,8 - 101,7)

**TABLE D
RECOMMENDED MATING
FLANGE BOLT TORQUES**

Installation

The TYCO Model BFV-300 Wafer Style Butterfly Valves may be installed with flow in either direction and can be positioned either horizontally or vertically. They are designed for installation between the faces of ANSI Class 125 and 150 flanges as well as PN10/16 flanges without the need for flange gaskets. The Series BFV-300 are self-sealing between mating flanges; therefore, they do not require the use of additional gaskets.

The Model BFV-300 may be installed with any pressure class or schedule of pipe or tubing no greater than schedule 40 that is listed or approved for fire protection service and installed in accordance with the manufacturers instructions.

The wafer bodies have locating lugs to ensure proper centering of the valve body when flange bolts are installed. Refer to Figure 2 for bolt diameter. Bolts and studs must meet the minimum strength requirements of ASTM A307 (Grade B), and the nuts must meet the minimum strength requirements of ASTM A563 (Grade A).

Prior to installation, close the valve. Spread the flanges apart to allow the valve to slip easily between the flanges. Make sure the pipe flange faces are clean of any foreign material such as scale, metal shavings, or welding slag. Insert the valve between the flanges (without flange gaskets). Do not apply lubricant to the seat faces as this may damage the seat material. Be sure to center the valve and do not damage the liner. Relax the separation of the flanges, install, and hand-tighten all flange bolts. Slowly open the valve, checking for free movement of the disc. If valve opens freely, leave the valve in the open position, and using a cross-

draw sequence, tighten all flange bolts until the valve is metal-to-metal with both mating flanges. Recommended tightening torques are listed in Table D.

Be certain to keep flange faces as parallel as possible during and after tightening bolts or studs. After final tightening, again check the valve for full opening and closing.

As applicable, refer to Figure 3 for the internal switch wiring diagram.

Conduit and electrical connections are to be made in accordance with the authority having jurisdiction and/or the National Electrical Code. With reference to Figure 3, the supervisory switch is intended for connection to the supervisory circuit of a fire alarm control panel in accordance with NFPA 72. The auxiliary switch is intended for the unsupervised connection to auxiliary equipment in accordance with NFPA 70, National Electric Code.

NOTE: For outdoor applications with internal supervisory switches, it is recommended that wiring connections be made at a temperature above 15°F (-9°C), in order to insure sufficient flexibility of the wire lead insulation.

Care and Maintenance

The TYCO Model BFV-300 Wafer Style Butterfly Valves must be maintained and serviced in accordance with this section.

Before closing a fire protection system control valve for maintenance or inspection work on either the valve or fire protection system which it controls, permission to shut down the affected fire protection systems must be obtained from the proper authorities and all personnel who may be affected by this decision must be notified.

The owner is responsible for the inspection, testing, and maintenance of their fire protection system and devices in accordance with the applicable standards of the National Fire Protection Association (e.g., NFPA 25), in addition to the standards of any authority having jurisdiction. Contact the installing contractor or product manufacturer with any questions. Any impairment must be immediately corrected.

It is recommended that automatic sprinkler systems be inspected, tested, and maintained by a qualified Inspection Service.

Limited Warranty

For warranty terms and conditions, visit www.tyco-fire.com.

Ordering Procedure

Model BFV-300 Wafer Style Butterfly Valves

With Internal Normally Open Supervisory Switches

Specify: (specify size) Model BFV-300 Wafer Style Butterfly Valve, Internal Normally Open Supervisory Switches, P/N (specify per Table A)

Without Supervisory Switches

Specify: (specify size) Model BFV-300 Wafer Style Butterfly Valve, P/N (specify per Table A)

Replacement Parts

Refer to Figure 2 to identify parts.

NOTE: Only items described in this section are offered as replacement parts.

Mounting Bracket Assembly with Bernstein External Switch

Specify: Mounting Bracket with Bernstein (specify model per Table B) External Switch, (specify size) Model BFV-300 Wafer Style Butterfly Valve, P/N (specify per Table B)

Handwheel with Pin

Specify: Handwheel with Pin, (specify size) Model BFV-300 Wafer Style Butterfly Valve, P/N (specify per Table C)

