

8. Mod. TAPÓN

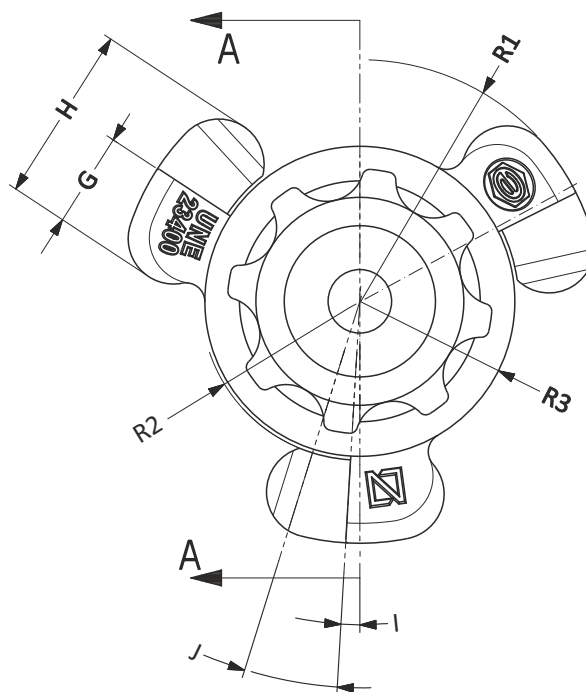

Ø NOMINAL	MATERIAL	REFERENCIA
25 mm.	ALUMINIO ESTAMPADO	<input checked="" type="checkbox"/> T 25U
25 mm.	LATÓN PULIDO	T 25L
45 mm.	ALUMINIO FUNDIDO	T 45AF
45 mm.	ALUMINIO ESTAMPADO	<input checked="" type="checkbox"/> T 45U
45 mm.	LATÓN PULIDO	T 45L
70 mm.	ALUMINIO FUNDIDO	T 70AF
70 mm.	ALUMINIO ESTAMPADO	<input checked="" type="checkbox"/> T 70U
70 mm.	LATÓN PULIDO	T 70LFP
100 mm.	ALUMINIO ESTAMPADO	T 100U

Producto Certificado por AENOR , según norma UNE 23400

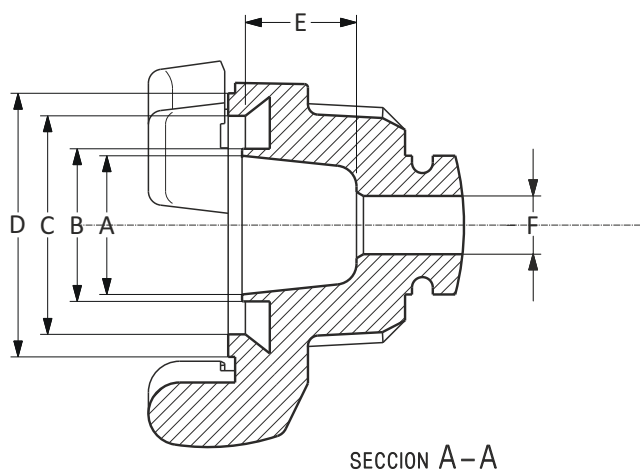

	A	B	C	D	E	F	G	H	I	J	R1	R2	R3
RACOR Ø25	20 ⁰ _{-0,75}	22 ± 0,4	31,5 ± 0,5	38 ± 0,75	16,5 ± 1	8,4 ^{+0,2} ₀	H/2	23,5 ⁺¹ ₀	2°30' ± 1°	14° ± 1°	31,25 ^{+1,5} ₀	21 ^{+0,75} ₀	19,5 ⁺¹ ₀
RACOR Ø45	37 ⁰ _{-0,75}	39 ± 0,4	48 ± 0,5	55 ± 0,75	24,5 ± 1	8,4 ^{+0,2} ₀	H/2	32,5 ⁺¹ ₀	5° ± 1°	12°30' ± 1°	44,25 ^{+1,5} ₀	31 ^{+0,75} ₀	29 ⁺¹ ₀
RACOR Ø70	61 ⁰ _{-0,75}	64,5 ± 0,4	74,2 ± 0,5	80 ± 0,75	29 ± 1	8,4 ^{+0,2} ₀	H/2	43,5 ⁺¹ ₀	4°30' ± 1°	13° ± 1°	59,25 ^{+1,5} ₀	44 ⁺¹ ₀	42 ⁺¹ ₀
RACOR Ø100	88 ⁰ _{-0,75}	94 ± 0,5	106 ± 0,5	116 ± 0,75	54 ± 1	8,4 ^{+0,2} ₀	H/2	54,5 ⁺¹ ₀	6° ± 1°	11° ± 1°	78,75 ^{+1,5} ₀	61 ⁺¹ ₀	58,5 ⁺¹ ₀