



WFDEN Series Waterflow Detector

The System Sensor WFDEN series is compatible with pipe diameters ranging from 50mm through 200mm and can be mounted in a vertical or horizontal position.



Features

- Compliant with Construction Products Regulation
- New directional cover allows installers and inspectors to easily see the direction of flow.
- European models are IP56 rated
- New cover provides a better seal, is lighter weight, not painted and corrosion resistant.
- Sealed retard mechanism immune to dust and other contaminants
- Less exposed metal reduces shock hazard, plastic cover acts as insulator and is resistant to arcing.
- Visual switch activation
- Audible switch activation (73 dBA)
- Field-replaceable timer/switch assembly.
- Accommodates up to 12 AWG wire
- 100 percent synchronization activates both alarm panel and local bell or horn strobe.
- Tamper-resistant cover screws
- Improved water sealing
- Reduced product weight
- Wire-ready terminals
- Improved wiring with new terminal block layout
- Snap-in optional cover tamper switch
- Timer repeatability
- Dial accuracy

The new **WFDEN Series** waterflow detectors from **System Sensor** consists of a rugged, IP56-rated enclosure that is more damage resistant than previous metal designs. The waterflow detector is designed for both indoor and outdoor use, with the widest available temperature range, from 0°C to 68°C (32°F to 55°F).

Models are equipped with tamper-resistant cover screws to prevent unauthorized entry. Inside, two sets of SPDT (Form C) synchronized switches are enclosed in a durable terminal block with new layout designed to make wiring easy with wire ready terminals, COM terminals are on a different elevation, large barrier between switches and easy to read raised textured lettering all make wiring easy. An optional cover tamper switch is available, securely snaps into place, no tools required.

The WFDEN series incorporates a mechanical time delay feature, which minimizes the risk of false alarm due to pressure surges or air trapped in the fire sprinkler system. The larger and easy to turn timer dial makes setting the waterflow detector easy with high contrast pad printed markings and three tabs to help with turning.

The WFDEN series is designed for accuracy and repeatability. The detector also offers improved performance during vibration in riser applications where detectors are exposed to a large in rush of water.

Agency Listings

Vds

CE



Waterflow Detector Specifications

Engineering Specifications

Vane-type waterflow detectors shall be installed on system piping as designated on the drawing and/or as specified herein. Detectors shall mount on any clear pipe span of the appropriate nominal size, either a vertical upflow or horizontal run, at least 15 cm (6 in) from any fittings that may change water direction, flow rate, or pipe diameter or no closer than 61 cm (24 in) from a valve or drain. The detector shall respond to waterflow in the specified direction after a preset time delay that is field adjustable. The delay mechanism shall be a sealed mechanical pneumatic unit with visual and audible indication of actuation. The actuation mechanism shall include a ethylene vinyl acetate vane inserted through a hole in the pipe and connected by a mechanical linkage to the delay mechanism. Outputs shall consist of dual SPDT switches (Form C contacts). Two conduit entrances for standard fittings of commonly used electrical conduit shall be provided on the detectors. A grounding provision is provided. Unless noted, enclosures shall be IP56-rated. All detectors shall be Factory Mutual for indoor or outdoor use.

Standard Specifications

Static Pressure Rating	LPC: 17.25 BAR (250 PSI) VdS: PN16 (16 BAR, 232 PSI)	Operating Temperature Range	32°F to 120°F (0°C to 49°C)
Maximum Surge	18 Feet Per Second (FPS)	Enclosure Rating*	IP56
Conduit Entrances	Two openings 22.2 mm (.875 in.) diameter. One open, one knock-out type	Cover Tamper Switch	Standard with ULC models, optional for UL and European models, part no. CTS
Contact Ratings	Two sets of SPDT (Form C) 10.0 A, ½ HP @ 125/250 VAC 2.5 A @ 6/12/24 VDC	Warranty	3 Years

Compatible Pipe

Model	Ref. Pipe Size mm (in.)	Triggering Flow Rate	Nominal Pipe O.D. (mm)		Wall Thickness (mm)	
			LPC	VdS	LPC	VdS
WFD20EN	50 (2)	47	60.3	60.3	3.6	2.3/2.9
WFD25EN	65 (2½)	49	76.0	76.1	3.6	2.6/2.9
WFD30EN	80 (3)	47	88.8	88.9	4.0	2.9/3.2
WFD40EN	100 (4)	53	114.1	114.3	4.5	3.2/3.6
WFD60EN	150 (6)	55	165.1	168.3	5.0	4.0/4.5
WFD80EN	200 (8)	64	219.1	219.1	6.3	4.5/5.9

WFDEN Field Wiring Diagram

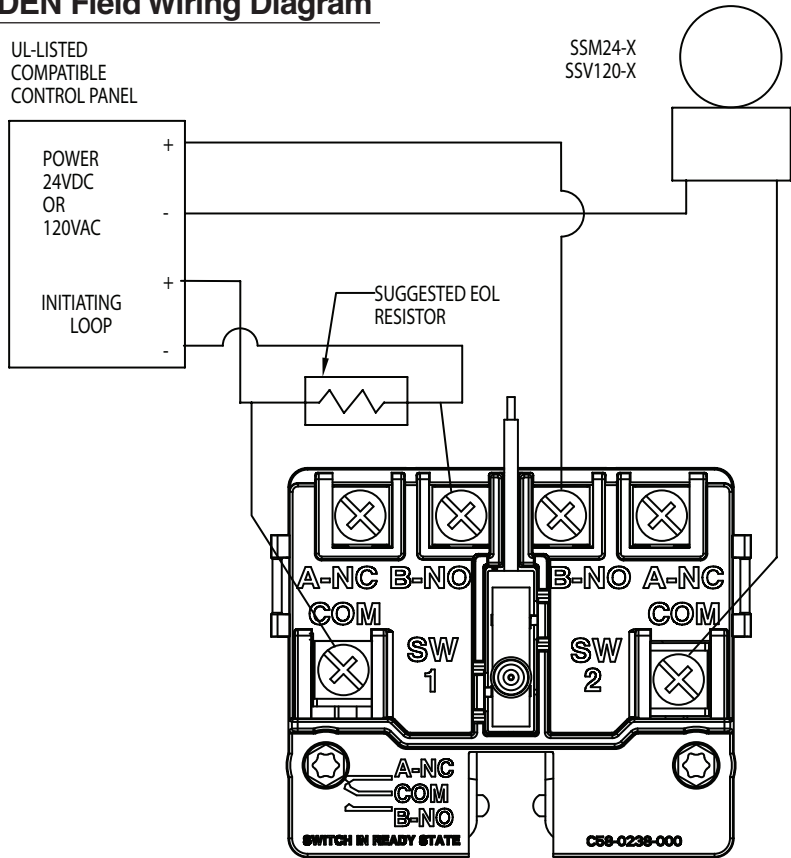

NOTE: COMMON AND B-NO CONNECTIONS WILL CLOSE WHEN VANE IS DEFLECTED, I.E., WHEN WATER IS FLOWING. DUAL SWITCHES PERMIT APPLICATIONS TO BE COMBINED ON A SINGLE DETECTOR.

CONTACT RATINGS	
125/250 VAC	10 AMPS
24 VDC	2.5 AMPS

SCHEMATIC OF INDIVIDUAL SWITCH IN "NO WATERFLOW" CONDITION

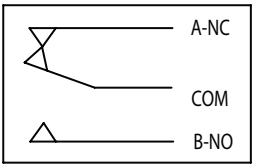

BREAK WIRE AS SHOWN FOR SUPERVISION OF CONNECTION. DO NOT ALLOW STRIPPED WIRE LEADS TO EXTEND BEYOND SWITCH HOUSING. DO NOT LOOP WIRES.

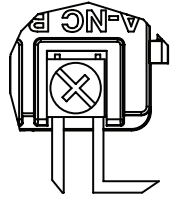

Delay Adjustment Dial

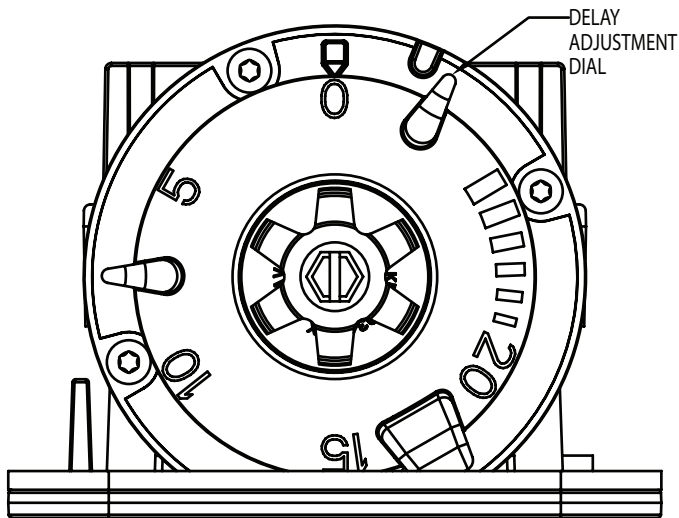

NOTE: NUMBER ON DIAL IS APPROXIMATE TIME DELAY IN SECONDS.

Overall Dimensions, Installed

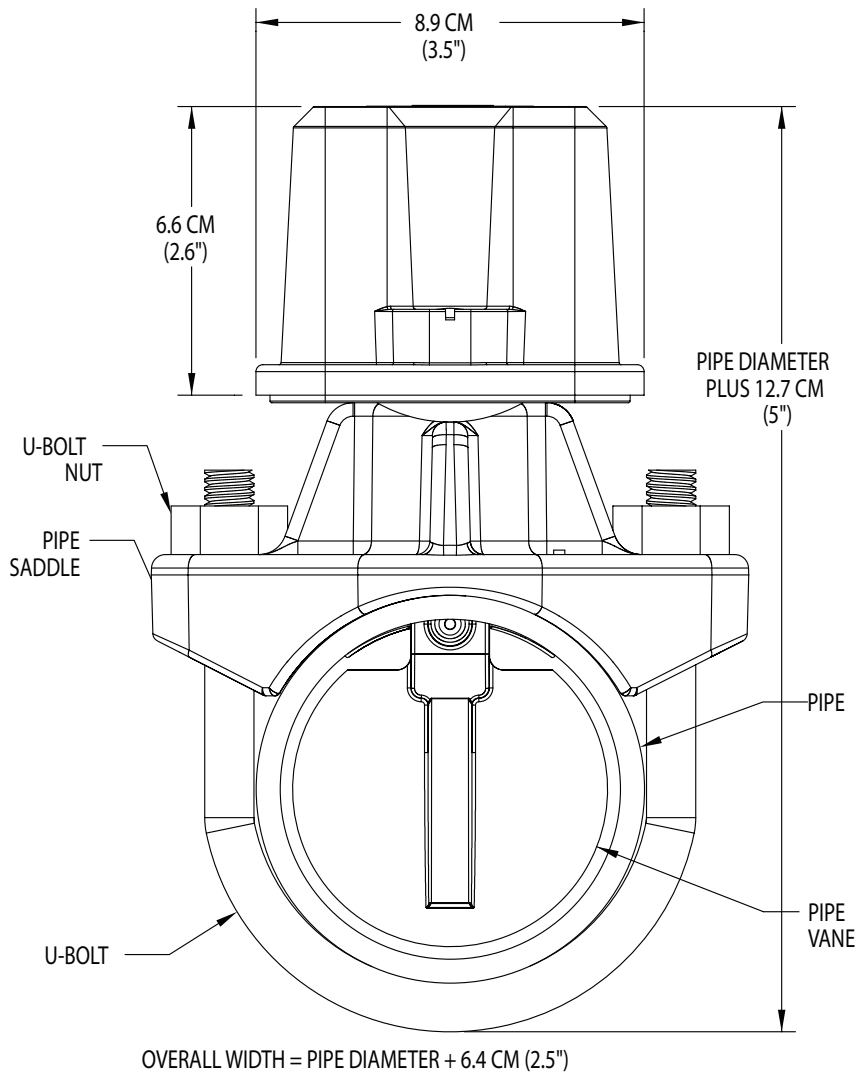

Ordering Information

UL Model	Pipe Size	Hole Size	Torque Setting
WFD20EN	50mm (2 in.)	31.8mm (1¼ in.)	40.7 - 47.5 NT-M (30 - 35 FT-LBS)
WFD25EN	65mm (2½ in.)	31.8mm (1¼ in.)	40.7 - 47.5 NT-M (30 - 35 FT-LBS)
WFD30EN	80mm (3 in.)	50.8mm (2 in.)	61.6 - 67.8 NT-M (45 - 50 FT-LBS)
WFD40EN	100mm (4 in.)	50.8mm (2 in.)	61.6 - 67.8 NT-M (45 - 50 FT-LBS)
WFD60EN	150mm (6 in.)	50.8mm (2 in.)	61.6 - 67.8 NT-M (45 - 50 FT-LBS)
WFD80EN	200mm (8 in.)	50.8mm (2 in.)	61.6 - 67.8 NT-M (45 - 50 FT-LBS)

Accessories

CTS	Tamper-proof switch kit
WFDW	Tamper-proof wrench for cover

*Maximum pressure rating 400 psi as approved by Factory Mutual.



3825 Ohio Avenue • St. Charles, IL 60174
Phone: 800-SENSOR2 • Fax: 630-377-6495
www.systemsensor.com

©2015 System Sensor.
Product specifications subject to change without notice. Visit systemsensor.com
for current product information, including the latest version of this data sheet.
WFDS44501 • 5/15