

# DC108

## Surface, overhead, floor mount contact

### Overhead door magnetic contact

---

The DC108 series overhead door magnetic contact is for use in the rigorous environments of commercial and industrial installations. The floor mount units are constructed with a low profile heavy cast aluminium housing. The reed switch assembly is fully encased in an exclusive polyurethane potting material to prevent damage due to moisture or humidity.

### Easy installation

---

A wide operating gap distance of up to 7.5 cm makes installation easy and helps prevent false alarms caused by door movement or damaged and loose fitting doors.



### Details

---

- Miniature, low-profile design
- Stainless steel armoured cable for added security, reliability
- Wide working gap for overhead doors
- Small size less likely to be damaged by forklifts
- Tamper loop provided

# DC108

## Surface, overhead, floor mount contact

### Technical specifications

#### General

Application type	Overhead
Contact type	NC
Connectivity	4 wires, 2 m

#### Wired/wireless

Wired-wireless	Wired
----------------	-------

#### Physical

Colour	Metallic silver
Material	Aluminium
Dimensions magnet	89 x 38 x 38 mm
Dimensions contact / sensor	89 x 38 x 38 mm
Operating gap	75 mm

#### Standards & regulation

EN50131 grade	Grade 2
Certification	IMQ, ULC

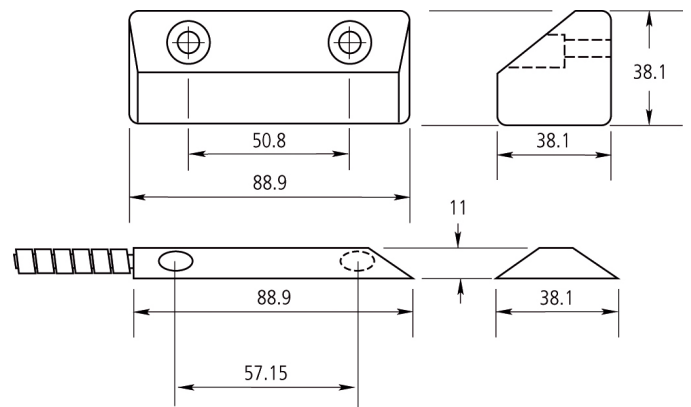

As a company of innovation, Carrier Fire & Security reserves the right to change product specifications without notice. For the latest product specifications, visit [firesecurityproducts.com](http://firesecurityproducts.com) online or contact your sales representative.

